

RADIO

JUNE, 1944

Design • Production • Operation

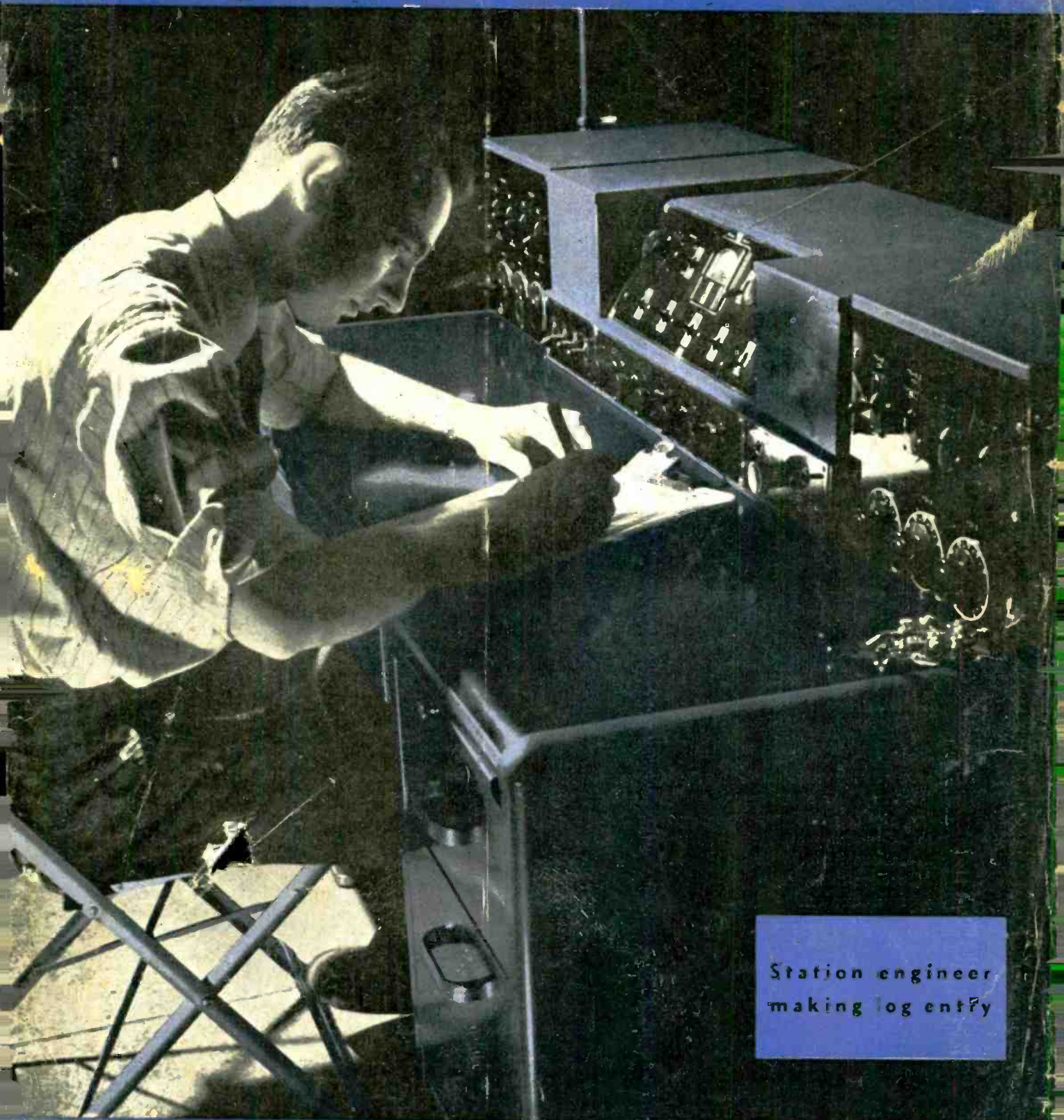

Station engineer
making log entry

The Journal for Radio-Electronic Engineers



PROVING GROUND FOR EVEN BETTER
"RAYTHEONS" TOMORROW!

Electronic tube developments are being refined in the crucible of war at an amazing rate. Raytheon engineers are originating new designs—manufacturing techniques are greatly stepped up, and many new applications for electronic tubes have been found—applications that will contribute much to the postwar era of electronics.

Raytheon's research and great wartime production record will doubly protect the tube requirements of

postwar radio and industrial electronic equipment manufacturers. As before the war, the postwar Raytheon tubes will reflect the best engineering for all applications, as well as all the "Plus-Extra" performance qualities that have been synonymous with the name of Raytheon throughout the years.

Raytheon Production Corporation

Newton, Massachusetts • Los Angeles • New York
 Chicago • Atlanta



All Four Raytheon Divisions Have Been Awarded Army-Navy "E" Plus Stars

RAYTHEON

High Fidelity

RADIO AND ELECTRONIC TUBES



DEVOTED TO RESEARCH AND MANUFACTURE OF TUBES FOR THE NEW ERA OF ELECTRONICS

FIRST ON THE NORMANDY COAST

The Army's SCR-299's went ashore with the wave of Allied assault troops that split the 2nd front wide open. These mobile radio units rolled up on the beachhead early in the battle to serve as vitally important front line communications weapons to coordinate and direct the striking power of the land, sea and air forces. . . . In truck or duck, the Hallicrafters-built SCR-299's go anywhere and are sturdy enough to withstand front line action. Highly dependable and powerful, they "get the message through."

hallicrafters RADIO

THE HALLCRAFTERS CO., MANUFACTURERS OF RADIO
AND ELECTRONIC EQUIPMENT, CHICAGO 16, U. S. A.



BUY A WAR
BOND TODAY!



Meeting the CALL for MORE and still MORE

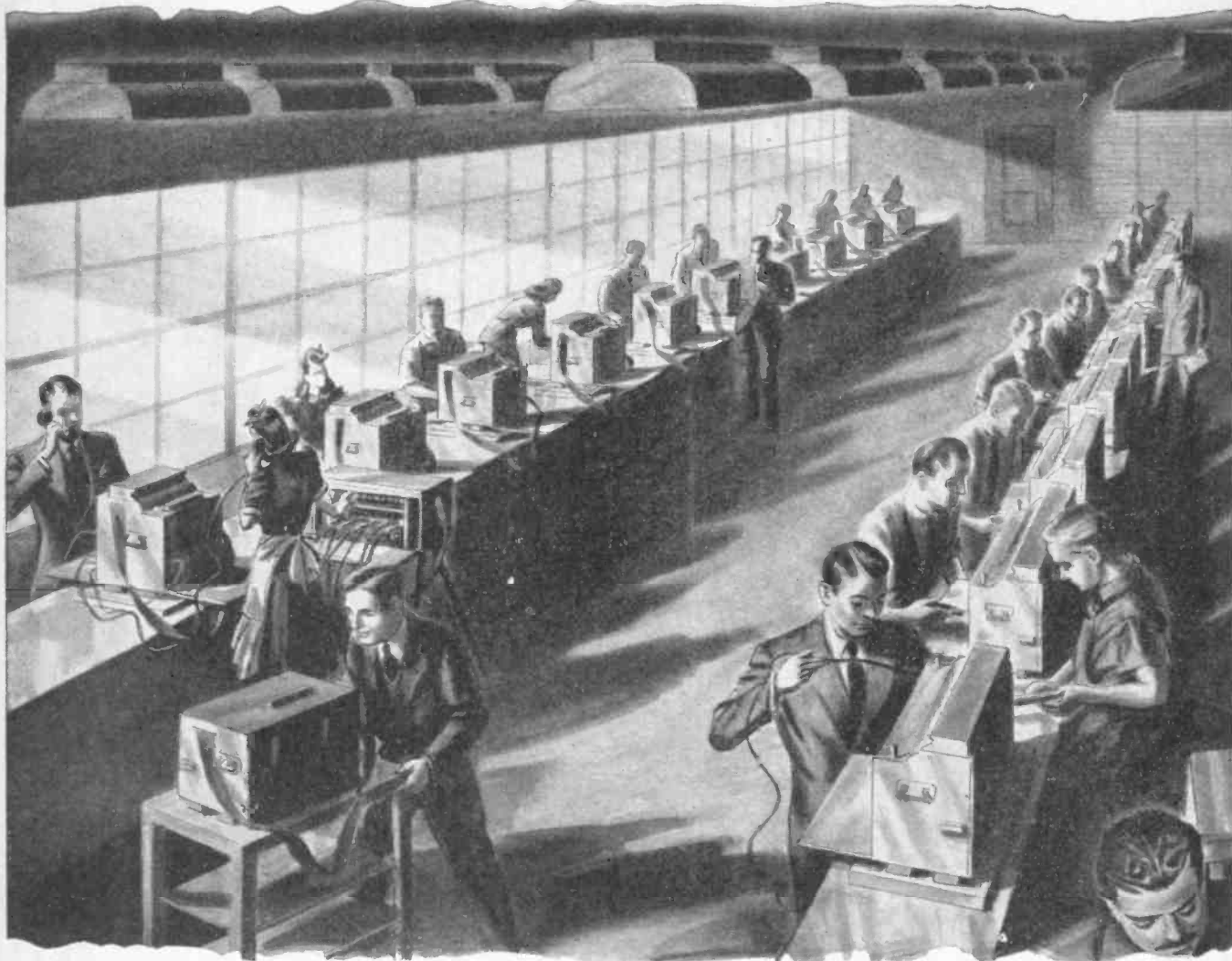

This year our armed forces need thirty-five per cent more communications equipment than in 1943. The men and women of this division are tackling their share of this biggest assignment yet, with the same enthusiasm they have shown from the start... and with three years' practical experience behind them.

They have good reason to be enthusiastic, for pictures, news stories, and soldiers returning from all over the world, tell of the heroic use that is being made of the equipment we turn out.

Here is a group of skilled engineers, designers and production people who are proving their ability to handle a big and difficult assignment. We tell about it here because we think that is the kind of organization you will want to have working on your postwar needs, such as:

COMMUNICATIONS SYSTEMS • SIGNALING EQUIPMENT
PRODUCTION CONTROL EQUIPMENT AND INSTRUMENTS
HOSPITAL SYSTEMS • ELECTRONIC EQUIPMENT • PRECISION
ELECTRICAL MANUFACTURING • IGNITION SYSTEMS

CONNECTICUT TELEPHONE & ELECTRIC DIVISION

GREAT AMERICAN INDUSTRIES, INC.

Meriden, Connecticut



RADIO

Published by RADIO MAGAZINES, INC.

John H. Potts Editor

Sanford R. Cowan Publisher

JUNE 1944

Vol. 28, No. 6

CONTENTS

COVER

A station engineer makes entries between program breaks at a transmitter's control desk. (Courtesy of Western Electric Co.)

ARTICLES

Circuit Relations in Directional Broadcast Transmitting Arrays— <i>H. E. Ennes</i>	18
Heterodyne Frequency Meter— <i>Albert H. Carr</i>	24
Characteristics of Radio Wire and Cable, Part 2— <i>J. M. Caller</i>	28
Factors Involved in Choosing Tube Types, Part 2— <i>A. C. Matthews</i>	32
Radio Design Worksheet: No. 26—Phase-Modulated Waves	35
Radio Bibliography: 16—Transmitters— <i>F. X. Rettenmeyer</i>	42

MISCELLANEOUS

Transients	5
------------------	---

TECHNICANA

Indicator Tube as Null Detector	6
UHF as an Aid to Meteorology	12
Potential Divider Design	14
Characteristics of Antennas	16
Harmonic Synthesis	60
Standard Frequency Source	60
Saving Power of CW Transmitters	60
This Month	37
New Products	39
Advertising Index	68

Executive & Editorial Offices

342 MADISON AVENUE
NEW YORK 17, N. Y.

Telephone MUrray Hill 2-1346

John H. Potts *President*

Sanford R. Cowan *Sec'y-Treas.*

Charles H. Farrell *Adv. Manager*

Ann Linberg *Adv. Production*

Sylvia Bornkoff *Circ. Manager*

PACIFIC COAST REPRESENTATIVE

Lloyd B. Chappell,

427 West 5th St., Los Angeles, Cal.

GREAT BRITAIN REPRESENTATIVE

Radio Society of Great Britain,

New Ruskin House, Little Russell St.,
London, W.C. 1, England

RADIO Magazine (title registered U. S. Pat. Off.) is published monthly at 34 N. Crystal Street, East Stroudsburg, Pa., by Radio Magazines, Inc. Executive and Editorial Offices at 342 Madison Avenue, New York 17, N. Y. Subscription rates—United States and Possessions, \$3.00 for 1 year, \$5.00 for 2 years; elsewhere \$4.00 per year. Single copies 35c. Printed in U.S.A. All rights reserved, entire contents Copyright 1944 by Radio Magazines, Inc. Entered as Second Class Matter October 31, 1942, at the Post Office at East Stroudsburg, Pa., under the Act of March 3, 1879.

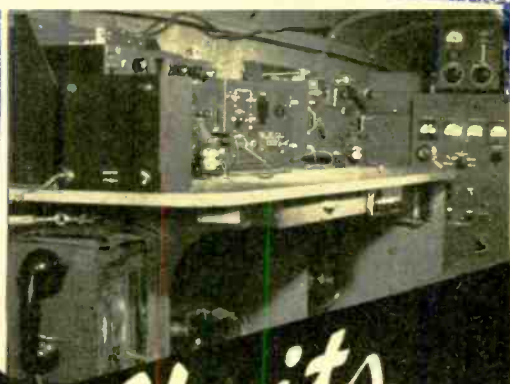
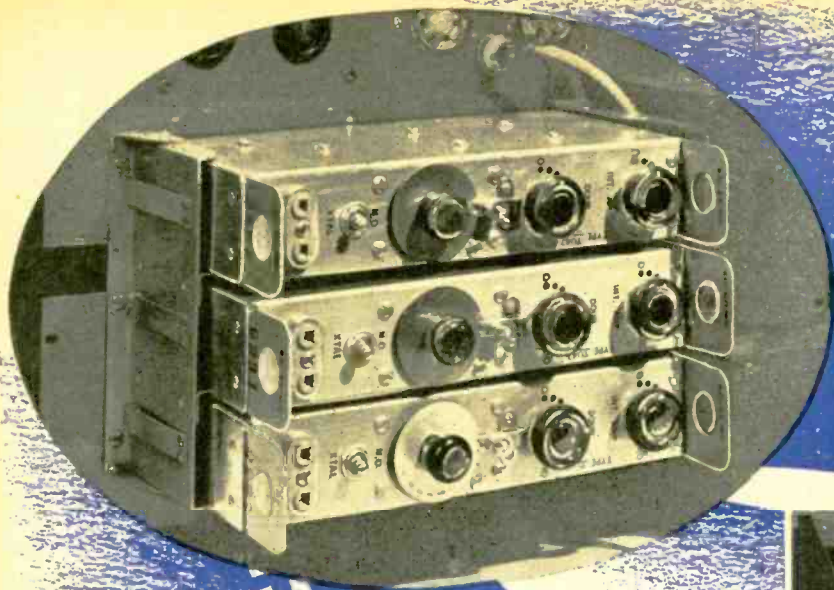

GUTHMAN

Super Tuning Units

IN THE FAMOUS SCR-299 MOBILE TRANSMITTER

We at Edwin I. Guthman & Company are proud of the Super Tuning Units that we manufactured completely in our splendidly equipped plant for the Hallicrafters' SCR-299 mobile transmitter. Operating under most trying combat conditions on all Allied Fronts, the SCR-299 has distinguished itself amongst America's most vital "weapons" . . . and always the Guthman Super Tuning Units rendered dependable and accurate service.

"GUTHMAN . . . Leader in INDUCTRONICS"

EDWIN I. GUTHMAN & CO., INC.

15 SOUTH THROOP STREET · CHICAGO

PRECISION MANUFACTURERS AND ENGINEERS OF RADIO AND ELECTRICAL EQUIPMENT



Transients

PRODUCTION ELECTRONICS

The prime factor in the industrial supremacy of our country has been the use of automatic machinery to perform manufacturing operations formerly done manually. The resulting saving in labor cost has enabled us to produce goods in quantity at a lower unit cost than foreign manufacturers who utilized manual labor from a much cheaper labor market. Our formula was simple, and it worked. Whether it will continue to work in the postwar period is open to question.

Let's see why. During the war, foreign manufacturers have been obliged to adopt our quantity production methods because they no longer enjoy the advantage of a cheap and plentiful labor market. Their engineers, too, have become proficient in working out methods of translating manual operations into mechanical ones. And it is unlikely that these manufacturers will revert to former methods after the war. Because our labor costs will undoubtedly continue to be higher, and we shall have lost some of the advantages of our better knowledge of automatic production methods, it appears that new methods of effecting production economy must be devised if we are to be able to compete in international markets. And this applies to national markets as well, because competition here—especially in the radio-electronic field—is going to be far greater than it was before the war.

One answer lies in a more imaginative approach to production problems and a wider use of electronic devices for quality control. Our production engineers have learned a great deal about methods of translating manual operations into mechanical ones and have been most successful in devising intricate machinery to do just this. But we need to dig a little deeper; we need first to determine whether the manual operation is the best approach to the problem. Take, for example, the electronic dish-washer. The design engineer might have made a motion study of an efficient housewife at work on the dishes and produce a contraption which performed the same manual operations. Instead, working with a free imagination, he developed a device which cremates electronically the remains of the feast, delivering the dishes dry-cleaned and sterilized. Similarly, the electronic precipitator; it doesn't remove dust from house furnishings, it traps the dust before it gets there.

In factory production control, "Go-No-Go" gages are universally employed for mechanical testing. Unless these gages are frequently replaced, due to wear, no accurate check is obtained and rejects accumulate. This job can be done electronically—and better. X-ray ex-

amination of castings for porosity, induction hardening, welding operations; these are but a few of the processes which point the way to a wider application of electronic devices throughout the entire field of industry.

TELEVISION PLANNING

While a great deal has been said about postwar television receivers, their application in merchandising, education and what-not, very little mention has been made as to the form in which television is to be presented. In particular, we'd like to know what plans are being formulated for the presentation of television in color, if any, and for stereoscopic television.

The latter has definite possibilities insofar as public appeal is concerned. The simple method whereby a stereoscopic effect is secured by color separation, though a failure when tried out in movies because the public just didn't care to put on specs, should be acceptable in home television receivers. After all, a great many sun-lamps have been sold, practically all of which require goggles to be worn.

The novelty and force of a stereoscopic presentation should be vital factors in creating a demand for higher-priced television receivers. If within the scope of the Radio Technical Planning Board, and not already under consideration, it might be worth while to add these items to the agenda.

Now that we've mentioned the RTPB, perhaps we should add that there is quite a squabble going on within the industry as to just what television standards the RTPB is going to recommend. Some say that these standards will be frozen at pre-war quality; others say no. In view of the fact that no recommendations have yet been issued by the Board, it seems a little unfair to prejudge the situation. Furthermore, it should be remembered that the function of the Board is simply to make recommendations to the FCC. It would seem, therefore, that the proper thing to do would be to present any complaints to the latter body, and at the proper time. We feel certain that the FCC will give sympathetic consideration to any valid objections before final action is taken.

EYEFULL IN GAUSSES

Now that a Radio-Radar Queen has been selected, why not keep going along these lines and choose a Radio-Electronics Queen?

This suggestion is based primarily upon the need for a reasonably valid excuse to utilize a perfectly good paragraph head.

—J. H. P.

ANDREW

No. 83

3/8" COAXIAL TRANSMISSION LINE



Type 83

QUICK DELIVERY can be made on this extremely low loss transmission line. Especially suited for RF transmission at high or ultra-high frequencies, it has wide application (1) as a connector between transmitter and antenna, (2) for interconnecting RF circuits in transmitter and television apparatus, (3) for transmitting standard frequencies from generator to test positions, and (4) for phase sampling purposes.

Andrew type 83 is a 3/8" diameter, air-insulated, coaxial transmission line. The outer conductor material is soft-temper copper tubing, easily bent to shape by hand and strong enough to withstand crushing. Spacers providing adequate mechanical support are made of best available steatite and contribute negligibly to power loss.

Accessory equipment for Coaxial Transmission Line, illustrated:

Type 853 Junction Box: Right angle box required where very sharp right angle turn is necessary.

Type 825 Junction Box: Three way T box for joining three lines at right angles.

Type 1601R Terminal: Gas tight end terminal with exclusive Andrew glass to metal seal. Incorporates small, relief needle valve for discharging gas.

Type 810 Connector: Cast bronze outer connector with copper sleeve for inner conductor.

Andrew Company manufactures all sizes in coaxial transmission lines, and all necessary accessories.

Write for Descriptive Catalog



Type 853

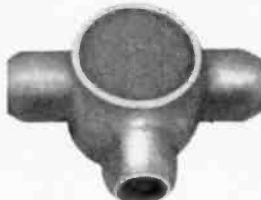

Type 825

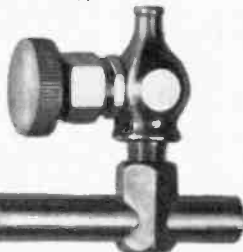

Type 1601R



Type 810



Andrew Type 83 (3/8" diameter) coaxial transmission line is manufactured in 100 foot lengths and may be purchased in coils of this length or in factory spliced coils of any length up to 1/2 mile.

ANDREW CO.



363 EAST 75th STREET
CHICAGO 19, ILLINOIS

INDICATOR TUBE AS NULL DETECTOR

★ An electron-ray tube may be used to indicate zero readings when measuring a-c or d-c voltage or insulation resistance in a bridge circuit and is claimed to provide greater sensitivity than a rectifier voltmeter used for the same purpose.

The sensitivity of the indicator tube is increased by the use of a cathode resistor to produce positive feedback, instead of the alternate methods of employing a separate amplifier.

This is discussed in the first of a series of two articles entitled "Universal Measuring Instrument." The first installment appeared in the May, 1944, issue of *Wireless World*.

In an a-c bridge this device will give a visible indication of 2 mv peak potential difference anywhere in the audio band. The circuit is shown in Fig. 1.

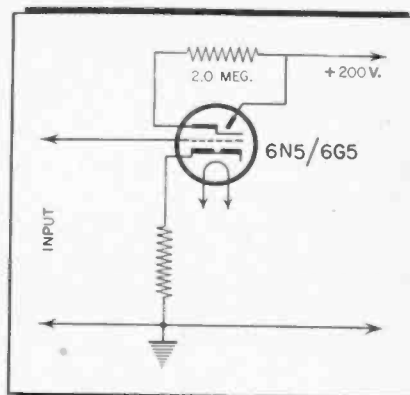

Figure 1

When neither side of the input can be connected to ground, a screened input transformer can be used.

When d-c voltages are involved, the circuit of Fig. 2 is recommended. The grid filter and cathode by-pass capacitor are required for d.c. A standard voltage of 100 volts is supplied to the potentiometer. A 120-v. neon tube voltage stabilizer is recommended, and the potentiometer must be calibrated but a voltmeter can be used, if desired, to measure the standard comparison voltage.

Zero input to the grid indicates equality between the unknown voltage and the output voltage from the potentiometer. For an accuracy of plus or minus 1%, the lowest measurable voltage is 0.5 volts.

A megohm bridge is shown in Fig. 3. The unknown resistance *X* is to be

[Continued on page 8]

NEW PROCESS Reduces Record-Making Time

[FROM ORIGINAL TO FINAL PRESSING]

to **11** minutes!



Tested with one of America's leading commercial record producers, Gray's molded modulation records may revolutionize popular record manufacture. Though the process will not be available until after the war, inquiries are invited from interested manufacturers of records.

Here is the process:

The original recording is embossed with a diamond stylus on a specially prepared metal disk. This can be immediately played back, without damage to the original.

This original serves as a mold to make a plastic stamper, under hydraulic pressure. No plating is involved. The stamping operation does not damage the metal original, and a number of stampers may be made, if necessary, from the one original.

The third and last step is pressing the final commercial records from the stamper. These records may be made on quite thin plastic, making possible filing several in the space now used by one standard record. These are flexible, easy to handle, and durable. The final records may also be made on blanks of standard thickness.

This new process gives high fidelity, and is equally efficient for all types and speeds of records — voice or music.



W. E. Ditmars, President

THE GRAY MANUFACTURING COMPANY

Makers of Telephone Pay Stations Since 1891
Hartford, Connecticut • 230 Park Avenue, New York

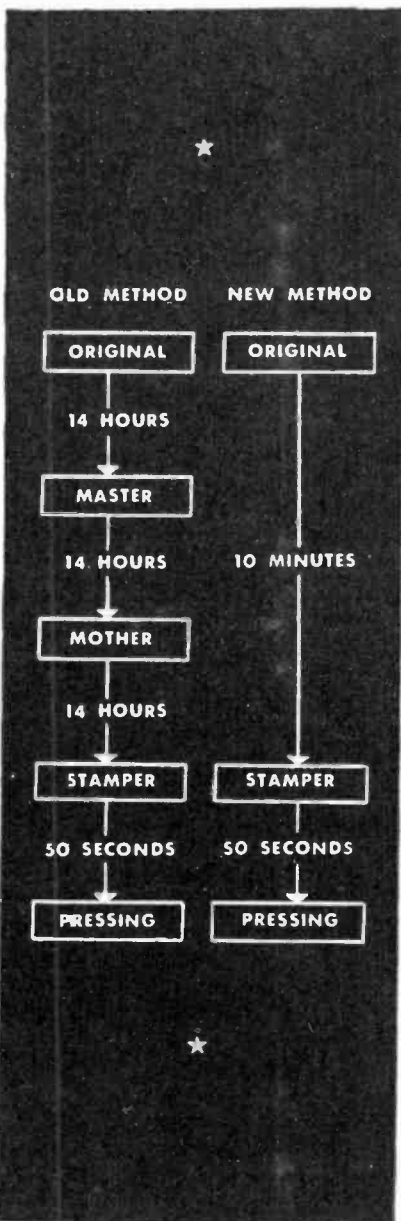

TECHNICANA

[Continued from page 8]

cator tube triode and reduce the gain, so the diode rectifier is employed for all general-purpose measurement work. This circuit is shown in Fig. 4.

The variable voltage from the potentiometer is applied as a slide-back voltage to the input, thereby reducing the anode current to a predetermined value. This anode current is passed through the 10-megohm resistor and the drop across the resistor applied to the indicator tube.

The sensitivity of the circuit depends upon the input impedance, which, in turn, depends upon the operating conditions of the diode. With zero anode voltage, some diode current will flow due to the initial energy of electrons leaving the cathode. This drives the anode slightly negative.

The slide-back voltage should be nearly, but not quite, equal to the input voltage, so the diode will operate with some current flowing through the load resistor. This current develops a practically constant direct voltage which corresponds to zero on the indicator tube.

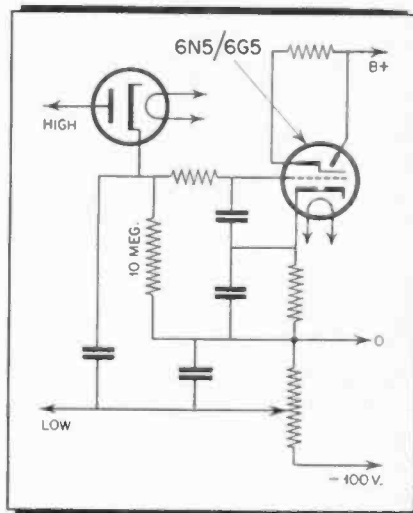

Figure 4

If excessive slide-back voltage is applied, the anode current will be zero and the input impedance will be higher. But the sensitivity of the indicator is lower.

A recommended figure for the bypass capacitance is .01 μ fd. The slide-back potentiometer resistance should be approximately 20,000 ohms for a reasonably low error. The input resistance may be approximately 0.1 megohm.

The accuracy of measurement is limited mainly by the stability of the in-

[Continued on page 12]



OUR SIGHT *is on your Future*

Today, behind closed doors, I. C. E. strives for perfection in the rush schedules of war... tomorrow, when the fruits of our labors have helped to win the peace, you can look to the precision engineering skill of I. C. E. to help mold your drafting-board dreams into reality. ☆ Perfected in the merciless crucible of war... I. C. E. will have the key to many of your post-war radio-application problems.

Electronics

... the promise of great things to come



INDUSTRIAL & COMMERCIAL ELECTRONICS
BELMONT, CALIFORNIA

More than Beauty here!

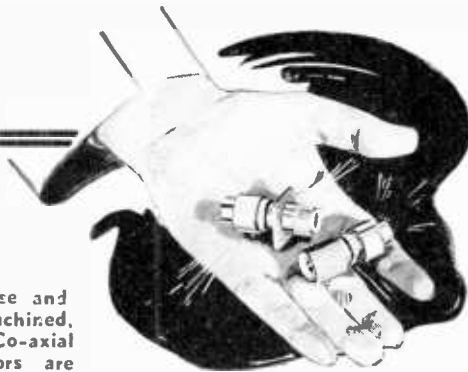

YES, we'll agree, these and other carefully machined, silver plated Astatic Co-axial Radio Cable Connectors are beautiful . . . so beautiful that you want to hold them . . . and "caress" them . . . in your hands. But they're more than beautiful! Astatic Co-axial Cable Connectors are products of engineering skill, machining precision, assembly care and expert finishing . . . all important to the efficient functioning of wartime radio communications equipment. Measuring up to the most exacting government and equipment-manufacturer standards, Astatic Connectors provide sturdy, lock-tight, insulated connections for strenuous wartime service. Yes, they're tough as well as beautiful . . . and they're dependable. We, their manufacturers, are proud of them. They'll do a swell job for you. Use them.

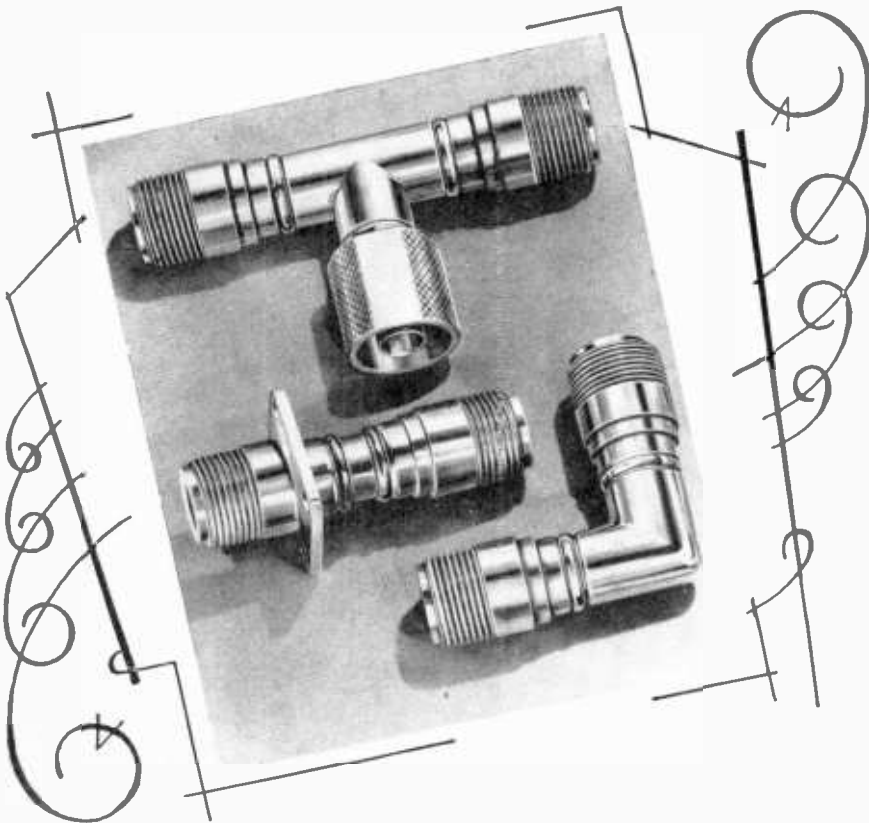

ASTATIC

IN CANADA:
CANADIAN ASTATIC LTD
TORONTO, ONTARIO

THE ASTATIC CORPORATION
YOUNGSTOWN, OHIO

TECHNICANA

[Continued from page 6]

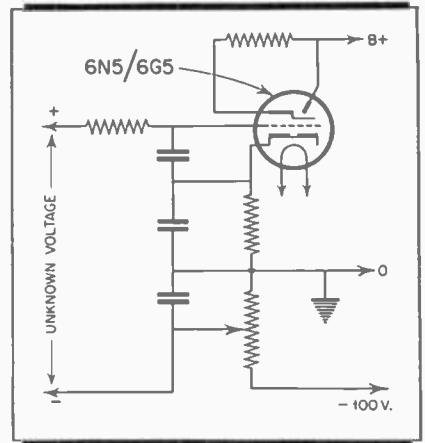

Figure 2

compared with R . For null, it is desired to have point B at ground potential. Then $E_1 - IX = 0$. Since

$$E_1 + E_2 = I(X + R),$$

$$E_1 + E_2 = \frac{E_1}{X} (X + R),$$

$$\text{or } E_2 X = E_1 R, \text{ and } R = X \frac{E_2}{E_1}.$$

By making either E_1 or E_2 100 volts, and varying the other, any resistance whatever can be measured. For accuracy, the value of R should be as close to the unknown resistance as possible, so for high-insulation resistance values precise measurements are difficult.

For capacitor insulation resistance readings, there is a slow drift due to charging of the capacitor.

At high frequencies the tube capacities shunt the anode load of the indi-

[Continued on page 10]

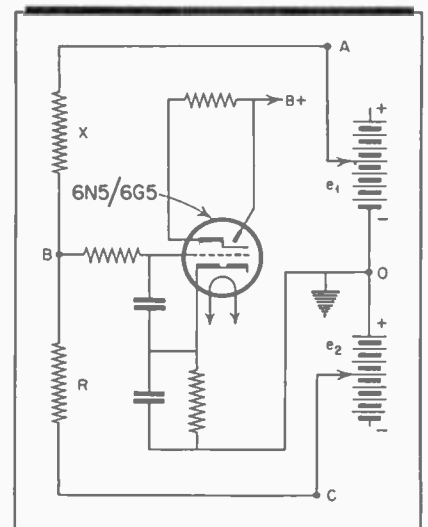
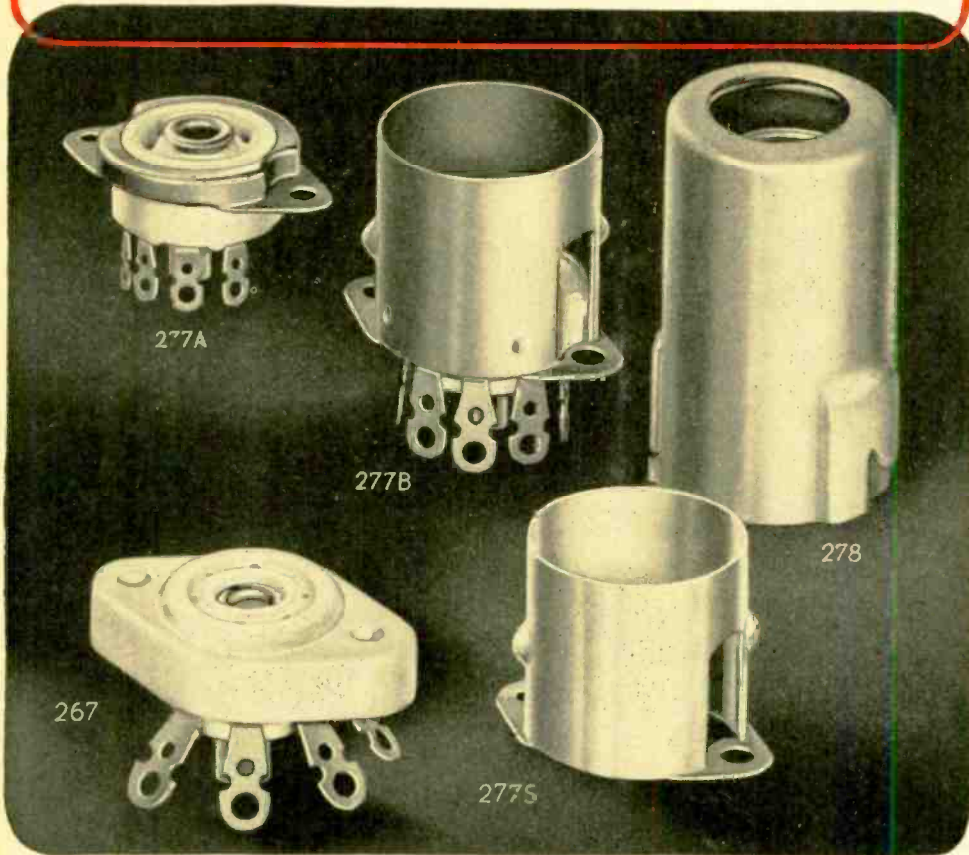

Figure 3

JOHNSON MINIATURE SOCKETS



Pre-eminent in the ceramic socket field, it was to be expected that Johnson was asked in 1941 to develop the first miniature ceramic socket (No. 267), or that it was quickly approved and widely adopted a year or more ahead of the field, and today is going into critical equipments by the hundreds of thousands.

The same Johnson skill in engineering both ceramics and metal has gone into the No. 277, and the associated shields and shield base (usable with other sockets as well). These Johnson sockets not only meet standards (developed jointly by us, the W. P. B. Socket Sub-committee, Signal Corps, Navy and private laboratories); in each of them you may count on that EXTRA value that's typical of products bearing the Viking mark. High grade steatite insulation with long creepage and arcing paths and low inter-contact capacity; accurately formed and processed contacts of silver plated beryllium copper or phosphor bronze, freely floating and with just the right tension, feature this series of sockets.

If you have a socket problem, whether it's engineering, design, substitution, or delivery, first try Johnson.
Ask for NEW catalog 968K



JOHNSON

a famous name in Radio

JOHNSON

Made

PLUGS and JACKS
INSULATORS
SOCKETS
CONDENSERS
INDUCTORS
BROADCAST
CABINETS

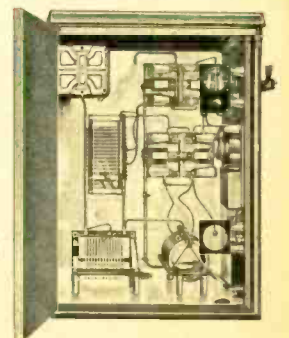
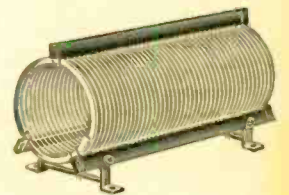
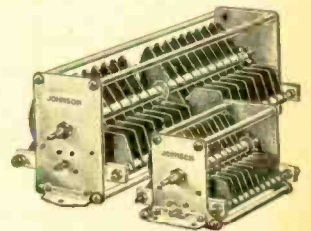
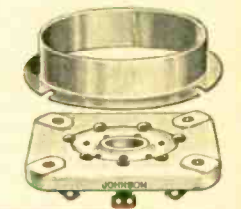
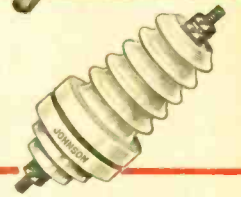
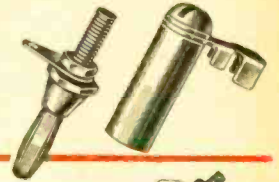

E. F. JOHNSON COMPANY • WASECA • MINNESOTA

RADIO * JUNE, 1944

wherever a tube is used...



for example

R. F. SHORT WAVE THERAPY

Radio Diathermy is used in therapeutic treatment of bruises, sprains, dislocations, arthritis, fractures, respiratory and sinus diseases. Oscillator type tubes generate the required high frequency.

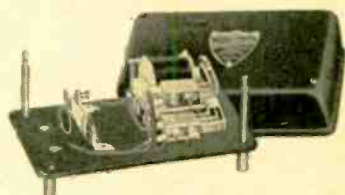

T-100 Laminated Time Delay Relay
Send for Bulletin R-5

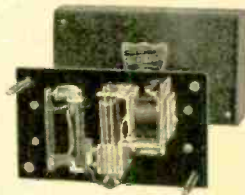

T-110 Time Delay Relay (not laminated)
Send for Bulletin R-5

THERE'S A JOB FOR

Relays BY **GUARDIAN**

The filaments of oscillator type tubes require a "warm up" of 20 to 30 seconds which is usually provided by a time delay relay such as Guardian's Type T-100. In this relay the time delay is adjustable between 10 and 60 seconds and is accomplished by means of a resistance wound bi-metal in series with a resistor. The contact capacity of the T-100 is 1500 watts on 110 volt, 60 cycle, non-inductive AC. The power consumption of coil and time delay during closing of the thermostatic blade is approximately 10 VA; after closing, 5.5 VA.

A similar relay giving almost the same performance but costing somewhat less is the Series T-110. This relay may be equipped with an extra set of open or closed contacts, if desired. In industrial control, both relays may be used in applications requiring the changing of circuits after a predetermined interval.

Consult Guardian whenever a tube is used—however—Relays by Guardian are NOT limited to tube applications but are used wherever automatic control is desired for making, breaking, or changing the characteristics of electrical circuits.

GUARDIAN  **ELECTRIC**
605-G W. WALNUT STREET CHICAGO 12, ILLINOIS
A COMPLETE LINE OF RELAYS SERVING AMERICAN WAR INDUSTRY



Distant flashes of lightning were used to magnetize needles by Joseph Henry during his experiments at Princeton in the 1840's. The needles were placed in coils attached to a metal roof and grounded. This little-known incident demonstrated to Henry that electromagnetic force was propagated — "wave-fashion."

Electronic research is an ever-unfolding drama that often magically turns into real-life factors—as Stancor engineers discover almost daily—and the values of which they build into the devices now being perfected for better coordination and control of communication.

SEND FOR NEW COMPLETE CATALOG

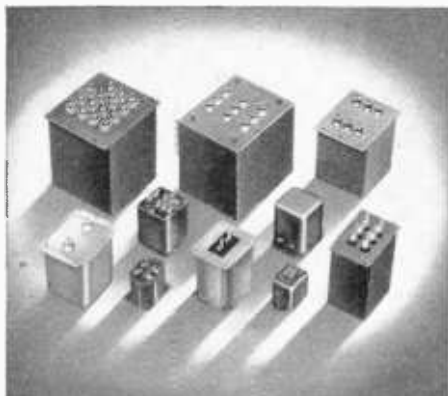

STANCOR

Transformers

STANDARD TRANSFORMER CORPORATION
1500 NORTH HALSTED ST. - CHICAGO 22



Manufacturers of quality transformers, reactors, power packs and allied products for the electronic industries.

initial bias on the diode anode, due to initial electron velocity. If the heater temperature is stabilized with a regulated filament supply, such instability will be largely overcome.

UHF AS AN AID TO METEOROLOGY

★ Reflection of ultra-short waves from meteorological discontinuities in the earth's troposphere suggests the use of u-h-f propagation in indicating weather conditions.

This is discussed in an article entitled "Wireless and Weather" which appears in the May, 1944, issue of *Wireless World*.

It is well recognized that so-called sky-wave reflections increase the range of transmission beyond the effective area of the ground wave. But with frequencies higher than about 50 megacycles, the sky wave does not ordinarily return.

Under normal atmospheric conditions the temperature and pressure, as well as water vapor content of the air,

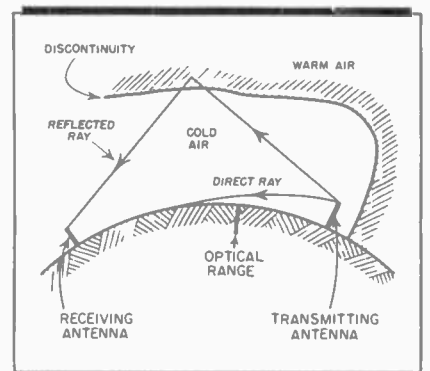

Figure 5

decrease with higher altitudes, resulting in a decrease in the dielectric constant of the air. This corresponds to a decrease in the refractive index. A "direct" wave, at a small angle, will be refracted toward the earth and increase the sending range to points beyond the optical horizon, even for ultra-high frequencies.

Under certain conditions the temperature may not decrease with higher altitudes. The same may be true of water-vapor content. When a high-frequency wave strikes a sharp discontinuity it may even be reflected back to earth. This effect is illustrated in Fig. 5.

In the article the author discusses the movements of air masses, such as the Polar and Tropical types. When such air masses move into the temper-

[Continued on page 14]

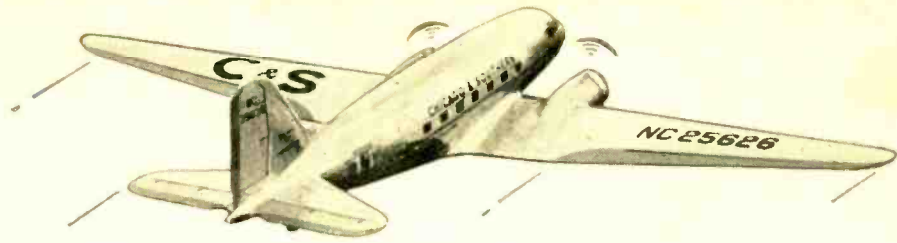

Chicago and Southern Air Lines *depend on* **WILCOX RADIO EQUIPMENT**

The "know how" that comes only with years of experience in research, experiment and proved production, is behind every piece of Wilcox equipment. Its reputation for reliable performance makes Wilcox preferred by major airlines. Military operations in all parts of the world today also utilize Wilcox installations for dependable communications.



**WILCOX
ELECTRIC
COMPANY**
Manufacturers of Radio Equipment
Fourteenth & Chestnut
Kansas City, Mo.



*Photographs,
courtesy Chicago &
Southern Air Lines*

TECHNICANA

[Continued from page 12]

ate climates and come in contact there are developed air fronts which are usually identified by the presence of rain, hail, snow, etc.

For several hundreds of miles ahead of the advancing front there are distinctive weather conditions. In particular, in advance of a warm front there can be expected a sharp discontinuity between cold and warm air masses, which extends up to 30,000 feet.

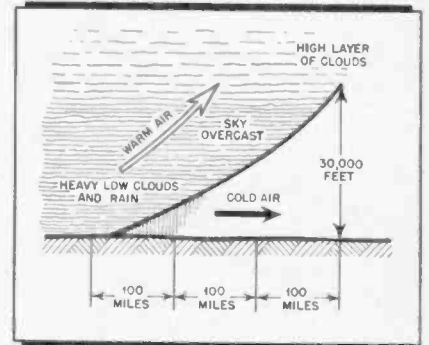

Figure 6

It is thought that such conditions might be capitalized upon by the detection and location of the advancing front, and measurement of the rate of advance, thus predicting the arrival of the storm. An experienced meteorologist would, of course, have to interpret the data obtained.

A section through a warm front is shown in Fig. 6.

POTENTIAL DIVIDER DESIGN

★ It is frequently required to calculate potentiometer resistance values when the output from the potentiometer cannot vary outside a given range for a given change in supply current. A simple formula is $I = I_{\max} - I_{\max} \cdot e/E$, where E = no-load volts with S_1 and S_2 open, e = "on load"

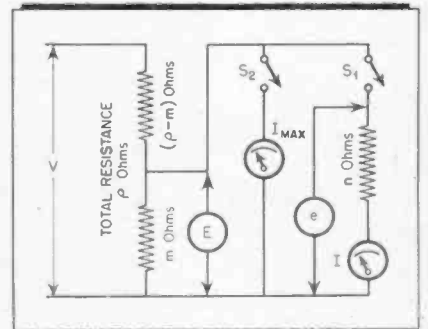
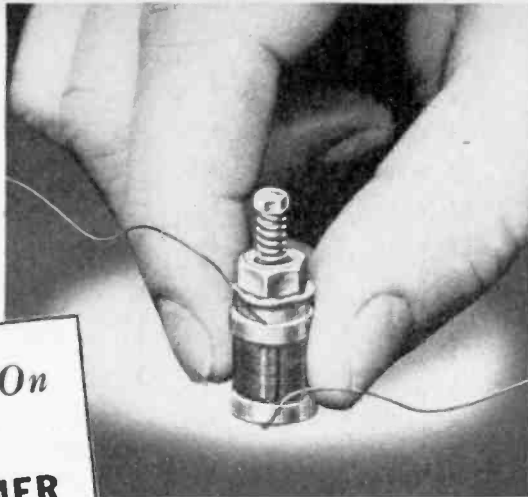

Figure 7

volts with S_1 closed, n = equivalent resistance of load, and I_{\max} = short-circuit current with S_2 closed. These quantities are indicated in Fig. 7.

[Continued on page 16]



The LS-1 shown above is actual size

Get The Story On
This
I-F TRANSFORMER

It may prove mighty useful to you. This small, precision built, permeability-tuned I-F Transformer, was developed, proved and is being used with outstanding success on a variety of vital war applications. Now available for more general use, it may be just what the doctor ordered for some of your present or projected components. Better have the complete facts on this simple, precise transformer readily available. Ask us about the LS-1 transformer.

CAMBRIDGE Thermionic CORPORATION

454 CONCORD AVENUE

CAMBRIDGE 38, MASSACHUSETTS

Built-in Precision



... Accuracy and dependability are built into every Bliley Crystal Unit. Specify **BLILEY** for assured performance.



BLILEY ELECTRIC COMPANY

UNION STATION BUILDING

ERIE, PA.



Sylvania was first to introduce a line of 1.4-volt tubes, which made the camera-type portable radio the rage of 1938 and later contributed to our military radio service.

Prior to this Sylvania development, the standard filament voltage for battery receivers was 2.0. This meant that two dry cells had to be connected in series to provide 3 volts. This power was reduced to 2.0 volts by means of a resistor, which dissipated one-third of the expensive voltage.

Sylvania 1.4-volt tubes operated, without resistor, on a

single dry cell. Their low filament drain made it possible to build combination receivers that took their power from either a 110-volt power line or a single dry cell.

This development, which is typical of Sylvania's leadership in engineering of economical standardization, went to war in portable radio equipment for close-range military communication. On every front 1.4-volt tubes reduced by half, the battery weight that our boys have to carry.

Quality that Serves the War Shall Serve the Peace

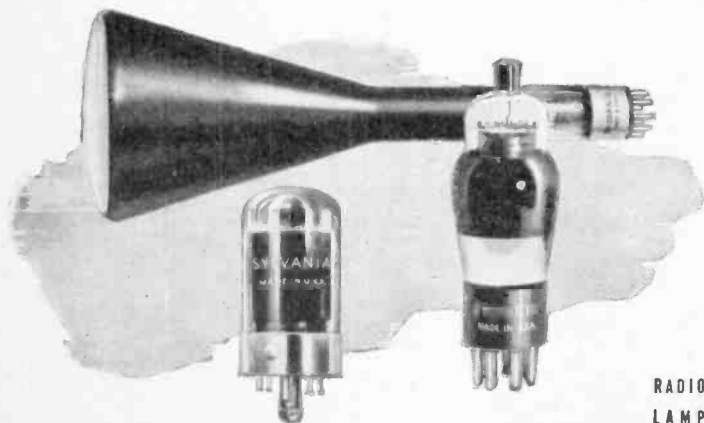

RADIO DIVISION

EMPORIUM, PENNSYLVANIA

SYLVANIA
ELECTRIC PRODUCTS INC.

RADIO TUBES, CATHODE RAY TUBES, ELECTRONIC DEVICES, FLUORESCENT LAMPS, FIXTURES AND ACCESSORIES, INCANDESCENT LAMPS

"Triple Six S"



MODEL No. 6665

All-Purpose Pocket Size Volt-Ohm-Milliammeter

A new modernistic styled, compact unit that provides an answer to all Volt-Ohm-Milliammeter requirements. Incorporates all the testing facilities of larger, more costly equipment. Self contained batteries. Selector switch control for all ranges. Completely insulated black molded case and panel. (Leather carrying case available for tester and accessories.)



TRIPLETT ELECTRICAL INSTRUMENT CO.

BLUFFTON • OHIO

BUS-BAR

Formed in
2 PLANES to
.001" ACCURACY

WITH
DI-ACRO

BENDER
No. 2



ONE-HALF
ACTUAL
SIZE

A heavy Copper Bus-Bar for panel board and terminal assemblies is illustrated, accurately duplicated in two planes with angles formed both flat and edgewise, across the material horizontally and vertically.

DI-ACRO Bender No. 2 has a forming radius up to 6" and capacity of 1/2" cold rolled solid steel bar or equivalent.

Send for Catalog
"DIE-LESS
DUPLICATING"

showing all models of DI-ACRO Benders, Shears and Brakes, and many examples of parts formed by "DIE-LESS DUPLICATING."

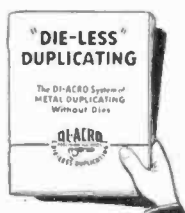

O'NEIL-IRWIN MFG. CO.

346 Eighth Ave. So.,
Minneapolis 15, Minn.

TECHNICANA

[Continued from page 14]

As an example of its use we are given a problem in which two tubes together draw 5 ma screen current and are fed with a potentiometer from 300 volts supply. The screen voltage should be 80. Strong a/c will reduce the screen current and the resulting increase in screen volts must be limited to 30.

Using the formula given we get 16,500 ohms for the upper arm and 9,500 ohms for the lower arm of the potentiometer.

This formula is developed in an article called "Potential Divider Design" appearing in the May, 1944, issue of *Wireless World*.

The formula is used as the basis for the construction of a graph, Fig. 8. This is used to determine the value of a potentiometer output voltage when only the potentiometer output current is known.

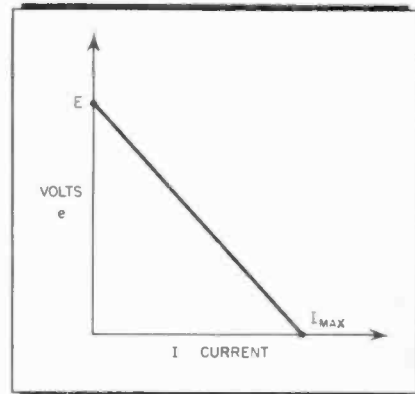

Figure 8

The curve is a straight line obtained from two points. One point is obtained by measuring I_{max} by shorting the potentiometer output with an ammeter. For I_{max} , $e = 0$. The second point represents the value of E when $I = 0$. This is measured as an open-circuit output voltage with a high resistance voltmeter.

Using this graph the output voltage can be determined for any value of load current.

CHARACTERISTICS OF ANTENNAS

★ R. E. Burgess of the British National Physical Laboratory discusses "Aerial Characteristics" in an important article in the April, 1944, issue of *Wireless Engineer*.

Mr. Burgess makes use of Helmholtz's definition of the principle of superposition, and Thévenin's theorem

[Continued on page 60]



In the Jungle ... **FORMICA MET THE TEST**

Thousands of American war planes, their vital electrical systems dependant on Formica insulating parts, have stood up to the humidity and heat of the jungle. They stood equally well the dry substratosphere cold on the way.

For Formica is available in insulating grades that do not change dimensions with changes in temperature, whose efficiency is not reduced by moisture absorption. Some of them permit very slight losses at high frequencies — and

they will do most of the work of ceramics. Yet they are easily and readily machined — adapted for fast mass production methods. War time experience has provided better insulating grades of Formica than were ever available before. Let us tell you about them now. "The Formica Story" is a moving picture in color showing the qualities of Formica, how it is made and how it is used. Available for meetings of engineers and business groups.



THE FORMICA INSULATION COMPANY, 4670 SPRING GROVE AVENUE, CINCINNATI, O.

RADIO ★ JUNE, 1944

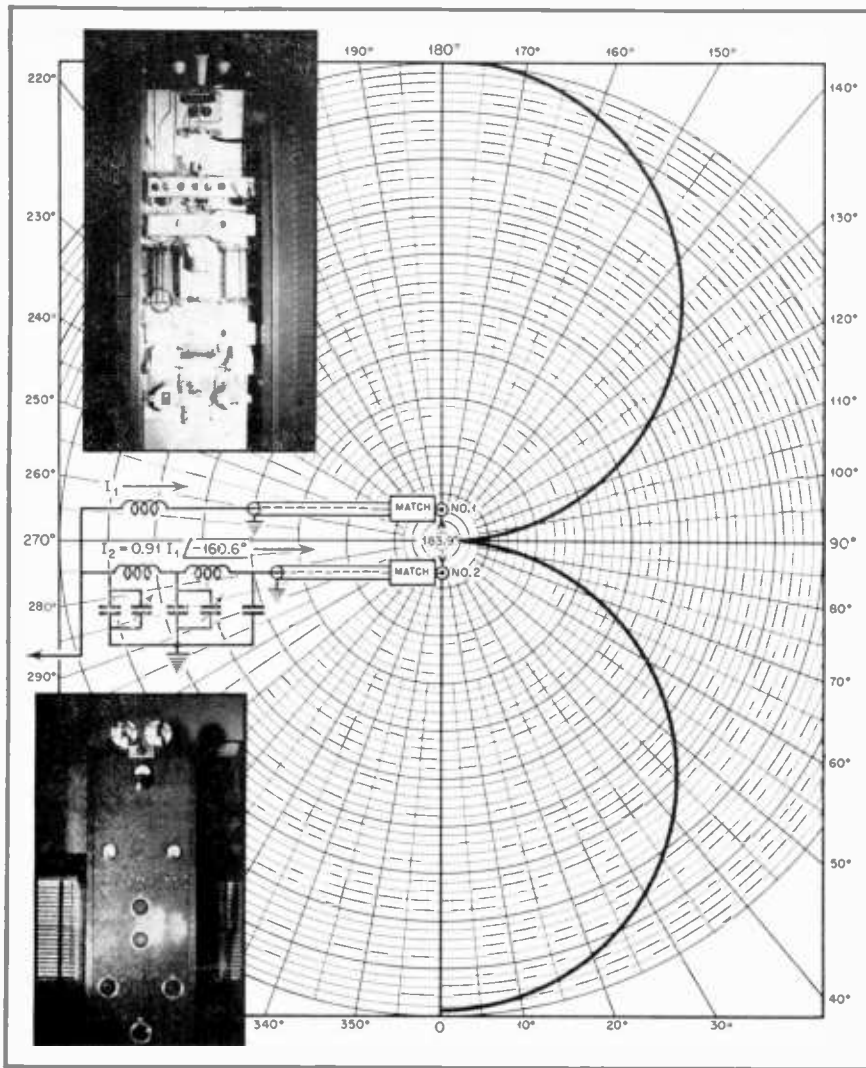

Fig. 1. Schematic and photographic illustration of two-element directional array at station WIRE

The theory of directional antenna arrays is reduced to a form which may be handled by ordinary circuit analysis, without the use of advanced mathematics

THE tremendous increase in the use of directional transmitting arrays during the past ten years is only a small scale forerunner of post-war transmitter practice. With the shift toward higher frequencies and the contemplated large-scale expansion of all types of radio services, the directional array will become more commonplace than the traditional single radiator.

The directive pattern is of two-fold purpose; energy directed into a desired direction with a gain in relative field strength, or, as is more often the case for broadcast stations, the prevention of radiation of more than a specified field strength in the direction of another station on the same channel. This feature also allows for an increase in power without effectively increasing the amount of shared channel interference.

Radiation Theory

Numerous articles treating the theory and practice of directional arrays have been published. Most of them have been treatises of radiation

theory based on Maxwell's Equations, providing detailed expressions in quantitative relationships of electric and magnetic fields associated with an arbitrary distribution of charge and current in the element under study. For instance, the total power of radiation is computed by assuming the system to be in the center of a very large sphere, and carrying out the summation of the power flow through each element of the area. Average intensity is then this derived total divided by the number of units of solid angle contained in the sphere.

This method of approach assumes a specialized study in higher mathematics beyond the scope of a large group of engineers and technicians interested in the subject. At the same time, it leaves entirely untouched the portion of the picture which reveals the contribution of each element in the array to the resultant pattern obtained and the interactions involved in the circuit used. The few papers published from the circuit theory standpoint,^{1, 2} have also assumed a rather advanced

knowledge of mathematical concepts.

It is therefore the purpose of this paper to reduce the theory of directional arrays, especially as applicable to broadcast frequencies, to a form that may be handled by ordinary circuit analysis. An attempt will be made by the use of circuit equivalents and analogs to show a picture of the function of self- and mutual impedances and radiation resistance as establishing the desired *modus operandi*. The mathematical approach will not go beyond algebraic and trigonometric solutions of complex numbers.

Definition of Terms

In order better to visualize the special method of attack to follow, it is well at this time to set up a definition of terms especially applicable to the approach.

Self-Impedance: The impedance offered to an applied voltage at an open terminal of the point in question, with no influence from any other antenna. For instance, the impedance function between base and ground of a tower radiator, such as is used in broadcast installations, may be shown to be analogous to the impedance function at the sending end of a transmission line equivalent in length to the effective height of the tower, and open-circuited at the receiving end. This antenna impedance function is illustrated in Fig. 2.

¹P. S. Carter, "Circuit Relations in Radiating Systems," *IRE Proceedings*, June, 1932.

²G. H. Brown, "Directional Antennas," *IRE Proceedings*, January, 1937.

Circuit Relations in DIRECTIONAL BROADCAST TRANSMITTING ARRAYS

HAROLD E. ENNES

Radio Station WIRE

The resistive component of the antenna impedance, which is the important factor of an antenna at resonance, must include heat loss, dielectric and ground losses, as well as the theoretical radiation resistance. A method will be devised to represent the radiation resistance as the load resistance of an equivalent circuit for purposes of circuit analysis. As may be deduced from the above discussion, the input impedance is equal to the self-impedance of the antenna when not influenced by another antenna. Self-impedance is designated by Z_{11} and is equal to E_1/I_1 .

Mutual Impedance: When one or more additional antennas are used, as in directional arrays, the input impedance of the first antenna is no longer equal to the self-impedance. The system now becomes equivalent to a coupled circuit, the number of meshes being dependent on the number of antenna elements. Since a voltage will now be impressed across the input terminals of the first antenna due to the current existing in the second antenna, we may establish the mutual impedance as

$$Z_{12} = -I_2/I_1 \dots \dots \dots (1)$$

E_2 is identified as the voltage induced in antenna 2 by antenna 1 when this induced voltage is referred to the reference point in antenna 2, and I_1 is the current at the reference point in antenna 1. In our discussion the reference point is the point of current loop.

Voltage and Current Relations

The voltage and current relations in the array may then be defined as

equivalent to that of the usual network with mutual impedances, thus:

$$\begin{cases} E_1 = I_1 Z_{11} + I_2 Z_{12} \\ E_2 = I_1 Z_{12} + I_2 Z_{22} \end{cases} \dots \dots (2)$$

where

- E_1, E_2 , etc. = voltages applied to antennas 1, 2, ...
- I_1, I_2 = currents in antennas 1, 2
- Z_{11}, Z_{22} = self-impedances of ant. 1, 2
- Z_{12}, Z_{21} = mutual impedances between antennas denoted by subscripts.

Driving-Point Impedance: The impedance offered to the exciting voltage of the first antenna when under the influence of the other elements in the array. Thus:

Driving-Point Impedance =

$$E_1/I_1 = Z_{11} + \frac{I_2}{I_1} Z_{12} + \frac{I_1}{I_1} Z_{11} + \dots (3)$$

and thus becomes equivalent to a multi-mesh network containing self- and mutual impedances.

Summarizing the theory as presented of self-, mutual, and driving-point impedances, we may establish the direct relationship between these characteristics. For example, self-impedance may be measured by open circuiting the elements in the array other than the one under measurement, making I_2 zero in equation (2). The impedance thus measured is then Z_{11} and equals E_1/I_1 , as shown. The self-impedance of each element is measured by this method. Then, with the second element closed, a two-mesh circuit results, and the measurement of the driving-point impedance will show the relationship of the self- and mutual impedances. Illustrating mathematically we have:

$$\begin{cases} E_1 = I_1 Z_{11} + I_2 Z_{12} \\ 0 = I_1 Z_{12} + I_2 Z_{22} \end{cases} \dots \dots \dots (4)$$

By simultaneous solution and obtaining E_2/I_1 we have

Driving-Point Impedance =

$$E_1/I_1 = Z_{11} - Z_{12}^2/Z_{22} \dots \dots (5)$$

Radiation Resistance: Since the loss of energy from the antenna by radiation must be accounted for in an equivalent circuit analysis, we may define this characteristic as a resistance which, when inserted at the current loop, dissipates an amount of energy equal to that radiated from the tower. Thus

$$R_R = P_o/I_o^2$$

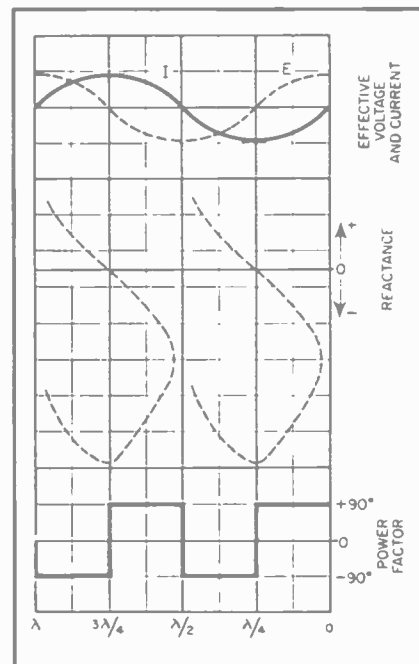

Fig. 2. Representation of the self-impedance function of an antenna

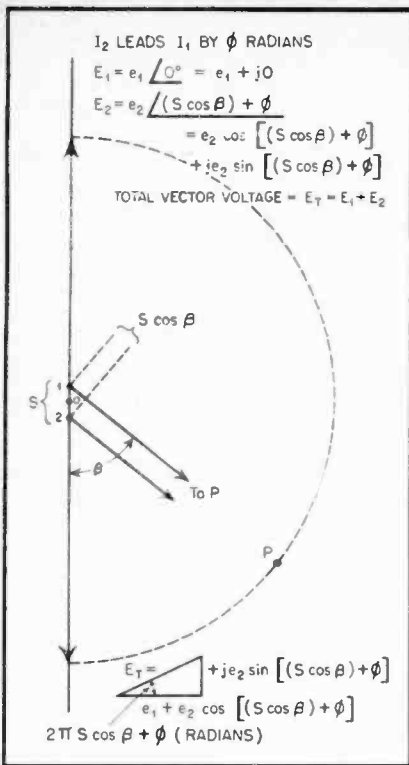

Fig. 3. In a two-element directional array, the resultant field strength is the vector sum of contributions from each element of the array

where I_0 = current at current loop
 P_0 = power radiated from antenna.

Basic Theory

It is now in order to review very briefly, in the most fundamental manner possible, the theory of a two-element directional array. Thus we will neglect propagation effects and consider only the directive characteristic.

From Fig. 3, it is observed that the

resultant field strength at P will be a vector sum of the contributions from each element of the array. P may be seen to be closer to antenna 2 by a certain number of electrical degrees, thus the signal E_2 will lead E_1 by that many degrees due to spacing S alone. The current I_2 also leads in time that of I_1 , by ϕ degrees, thus the lead of E_2 will be still greater at P by ϕ amount. In other words, the resultant voltage vectors at P will have a magnitude dependent on the currents in the respective elements, with an angular relationship determined by the time phasing in electrical degrees of the currents in the elements and the difference in path length from P to the respective antennas.

From the above discussion we may derive a relative field equation to obtain a picture of the resultant field pattern as a function of the parameters involved. If the current phase of antenna 1 lags antenna current in 2 by ϕ radians as shown, then the phase difference at any arbitrary point P about the array is $2\pi S \cos \beta + \phi$ radians, as is evident from Fig. 3. Then the relative field at P becomes:

$$E_{relative} = 2 \cos [(\pi S) \cos \beta + \phi/2] \dots (7)$$

If I_2 lags I_1 , then the equation becomes

$$E_{relative} = 2 \cos [(\pi S) \cos \beta - \phi/2]$$

Thus, in Fig. 4A, if $S = \lambda/4$ and $\phi = 90^\circ$ ($\pi/2$ radians), the resultant pattern is a cardioid as illustrated. I_2 leads I_1 by 90° , but in the direction of P_1 , it takes 90 electrical degrees to travel from antenna 2 to antenna 1. Therefore the fields add in this direction. In the direction of P_2 , however, it may be observed that I_1 starts $1/4$ of a cycle late and loses another $1/4$ cycle

in traveling to antenna 2, thus arriving at antenna 2 at 180° phase difference, cancelling radiation in this direction.

Similarly, Fig. 4B illustrates the pattern of a two-element array where $S = \lambda/2$ and $\phi = 180^\circ$ (π radians). By following the line of reasoning above, it may be seen that the two fields will add in the directions of P_1 and P_2 . At any other angle from the line of array, the resultant field is a quadrature addition of the two vectors as shown in Fig. 3. Equation (7) may be evaluated on polar paper for any given set of parameters. It is obvious, of course, that the evaluation of β from 0° to 180° is all that is necessary, due to the symmetry of the pattern.

Phasing Networks

Fig. 1 illustrates by photograph and schematic drawing the two-element directional array as installed at WIRE in Indianapolis.

The transmitter is the RCA 5-D, the final tank circuit being essentially as shown in Fig. 5. L_2 , L_3 and C_3 form a low-pass T network, and may be designed to match any transmission line 70 to 500 ohms for any operating frequency desired. All modern broadcast transmitters are similar in design in this respect and require no special matching network between final tank and transmission line. The matching network is therefore used at the coupling point of transmission line and antenna. In broadcast installations, lines are nearly always operated under non-resonant conditions, and this is assumed in all following discussions.

The network into which the final tank circuit is loaded is therefore the necessary phase-shifting and power-dividing network. Fig. 6 has been prepared for the special case where input and output impedances are equal as mentioned, and may be used to design a network that will shift the phase ϕ amount between 0° and 180° for any Z_0 . Data is given for both T and Pi sections. It should be remembered that a phase shift occurs in the transmission line of a uniform angle (under non-resonant conditions) of 360° for each electrical wavelength of line. However, due to a necessary spacing S required for a desired pattern, it is seldom feasible to use a line of exact length for a certain phase shift, hence the need for a phase-shifting network under absolute control.

Design Data

Although this article is by no means intended to be a comprehensive treatment of design technique for directive systems, this bit of design is presented with the hope that it will stimulate a healthy interest in the problems re-

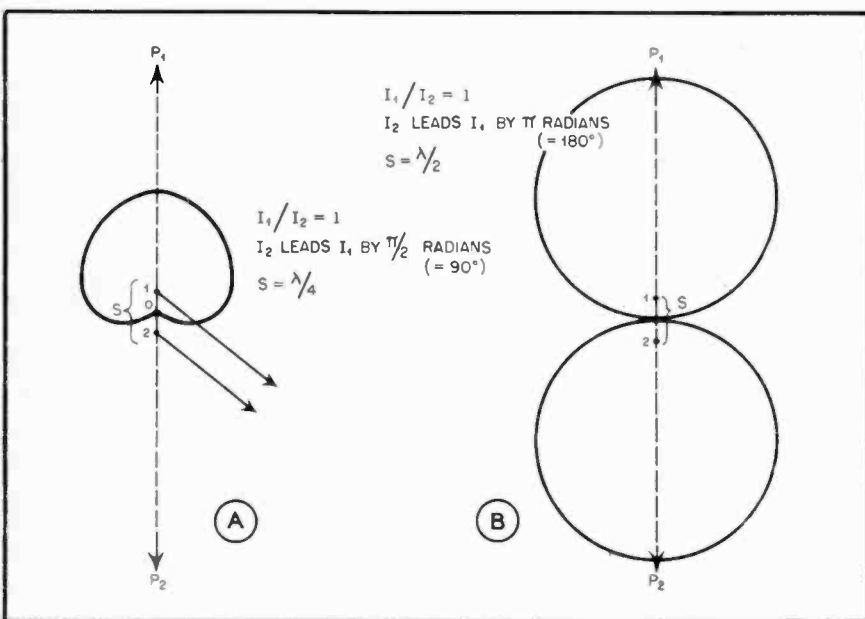

Fig. 4. In (A), pattern of two-element directional array when $S = \lambda/4$ and $\phi = 90^\circ$. In (B) pattern of array when $S = \lambda/2$ and $\phi = 180^\circ$

lating to phasing of elements in an antenna array.

As an example of the use of Fig. 6, assume

$$Z_o = 100 \Omega$$

$$\phi = 30^\circ$$

for a T section:

$$X_{L1} = X_{L2} = Z_o/a = 100/3.6 = 27.77 \Omega$$

$$X_C = -Z_o/b = -100/0.5 = 200 \Omega$$

Assume a frequency of 1000 kc

$$X_L = \omega L$$

$$\therefore L = X_L/2\pi f = 27.77/6.28(10^6) =$$

$$4.42(10^{-6}) = 4.42 \mu H$$

and $X_C = 1/\omega C$

$$\therefore C = 1/2\pi f X_C = 1/6.28(10^6) =$$

$$0.159(10^{-12}) = 0.159 \mu \mu F$$

Therefore:

$$\left. \begin{array}{l} X_{L1} = X_{L2} = 4.42 \mu H \\ X_C = 0.159 \mu \mu F \end{array} \right\} \begin{array}{l} \text{for } \phi = 30^\circ \\ \text{when } Z_o = 100 \Omega \end{array}$$

A T or Pi network of the type illustrated in Fig. 6 (where the series reactance is inductive) will cause a lagging current of ϕ degrees. For the same effect except that the current is made to lead instead of lag, the series reactance is made capacitive and the shunt arms inductive.*

Equivalents & Analogs

For purpose of special observation we may set up an analog (not necessarily equivalent) of a two-element array as in Fig. 7. Mesh 1 to the left of the common input terminals A-B, represents the main radiator, and mesh 2 represents the phasing unit and antenna 2. The mutual coupling is designated by M, which results in an additional impedance mutual to the two meshes and not represented in the circuit.

The problem is then to set up an analog of the entire circuit that will prove mathematically feasible to illustrate certain relationships in the circuit. This analog must represent the losses due to the capacity from the base of the tower to ground, dielectric hysteresis and ohmic resistance. Reactive components of the antennas at resonance are balanced out, and non-resonant transmission line, coupling and matching networks need only be assumed to contribute slight additional losses to be limped in our analog with resistance loss. Such a circuit may be set up as in Fig. 8.

It is obvious that this circuit is not an "equivalent" of a two-element array. It is, however, an analog set up to illustrate the mathematical relationship in common circuit form where the radiation resistance is represented as the load resistance of a network, modified by the mutual impedance of the circuit.

It may be observed that with mesh 2 open-circuited, Z_{12} will be zero (short circuit), and $Z_{11} = R_L + R_R$. Similarly with mesh 1 open-circuited,

$Z_{22} = R_L^2 + R_R^2$. With both meshes closed, Z_{12} will have a magnitude dependent on the spacing of the elements, and the resistive component of this impedance will vary with spacing as shown in Fig. 9. This is a composite graph of the mutual impedance function of vertical broadcast towers $\frac{1}{2}$ wavelength high, based on findings of G. H. Brown ("Directional Antennas," *IRE Proceedings*, Jan., 1937). For convenience the mutual impedance in the form Z_{12} / θ_{12} has also been plotted in the form $R_{12} \pm jX_{12}$ in order to show the function of the resistive component with spacing.

Effect of Antenna Coupling

It is obvious that under practical conditions, the coupling of a second antenna will modify the resonant frequency of the first antenna due to the reactive component of the mutual impedance. This must be compensated for just as the reactive component of the antenna is balanced out in loading adjustments. Therefore, this leaves us concerned only with the resistive component of the mutual impedance under properly loaded conditions at resonance. Thus, we may in this example substitute R_{11} , R_{12} and R_{22} for Z_{11} , Z_{12} , and Z_{22} respectively.

It is possible now to visualize the effect of the coupling of elements in the array on the resultant impedances and currents involved. The effective radiation resistance may be seen to be raised or lowered depending on the spacing, since from Fig. 9 it is observed that the resistive component of the mutual impedance is positive or negative at varying spacings. Conse-

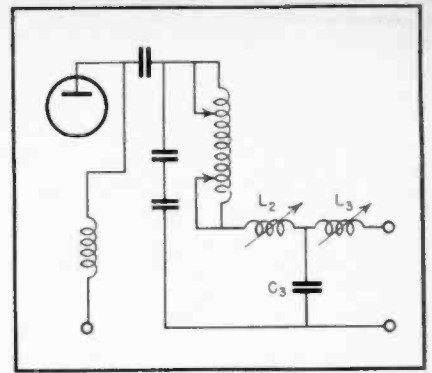

Fig. 5. Tank circuit schematic

quently, if the currents are held to a given value for varying spacing, the intensity of radiation perpendicular to the array will remain constant, but the total power will vary due to the effect of the mutual impedance change. In other words, the power in the antenna = $W = I^2 (R_{11} + R_{12})$. The power radiated is the $I^2 R$ drop across the radiation resistance R_R which may be large or small (depending on antenna efficiency) in ratio to R_L and R_{12} . This, of course, is simply one theoretical picture of an abstruse problem.

If $R_{11} + R_{12}$ is plotted on linear paper with spacing S as the abscissa, the contour of the power function will be traced. If P is taken as the power in one element to establish a given electric field and is taken as unity, and P^1 is the power necessary for the two-element array to maintain the ideal status quo of twice radiated field in maximum lobe (hence 4 times the power), then $P^1 = 2R_{11} + R_{12} / R_{11}$ and the gain = $4/P^1$. Thus, at the

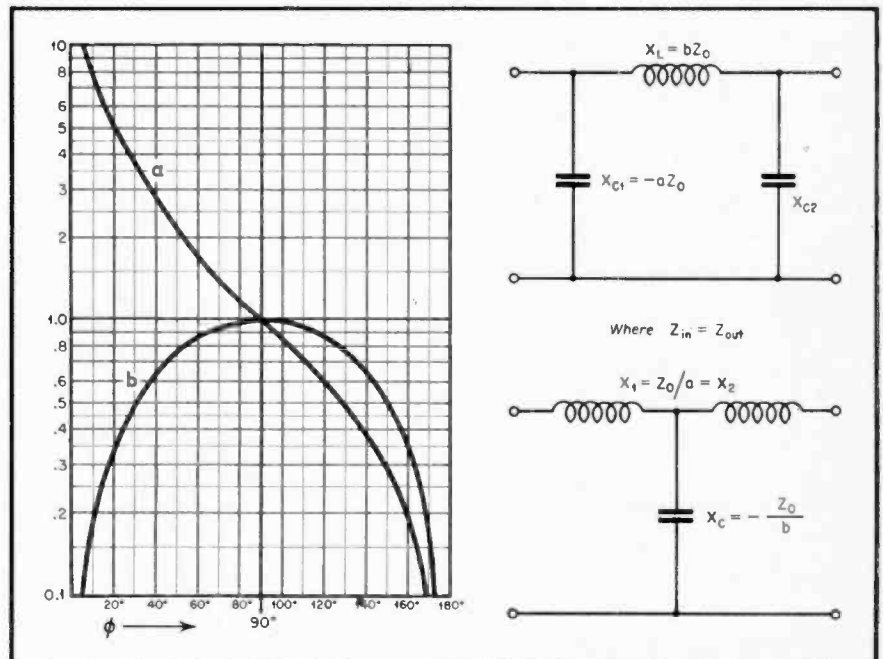

Fig. 6. Phase-shift characteristics of tank circuit networks

* Radio Engineers' Handbook (1943), Terman, pp. 210-212.

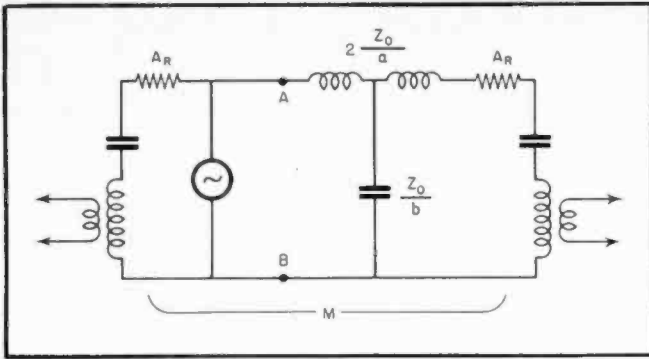

Fig. 7. Analog of two-element array

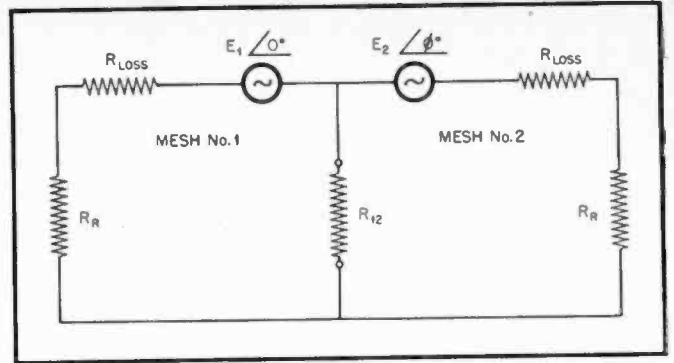

Fig. 8. Analog of array for mathematical analysis

spacing where $R_{11} + R_{12}$ (note that R_{12} may have to be subtracted rather than added), is a minimum as indicated on the graph, then the optimum spacing for maximum gain will be shown.

For example if $R_{11} = 100\Omega$ and $R_{11} + R_{12} = 80$ ohms, then $P^1 = 2 \times 80/100 = 1.6$ and the gain = $4/1.6 = 2.5$ times.

Rigorous Application

The circuit of Fig. 8 could be set up to include all the reactive components of the impedances for rigorous treatment and field application. Fig. 10 illustrates the usual method of treating the antenna array and its image, giving a picture of the gain of an antenna of arbitrary length above ground over that of the same antenna in "free space."

The currents in the array elements may then be represented as:

Therefore
$$\left. \begin{aligned} I_2 &= F I_1 / \phi \\ I_1 &= \frac{I_2}{F} / \phi \end{aligned} \right\} \dots \dots \dots (8)$$

where

- I_1 = rms current at current loop in ant. 1
- I_2 = same for antenna 2
- F = fraction showing relation of current magnitudes
- ϕ = phase angle of currents in 1 & 2

Applying equation (2) to the network of each element, including the

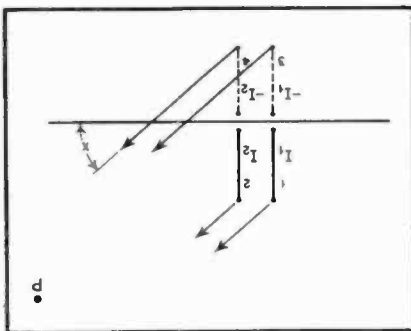

Fig. 10. Vector diagram of two-element array to represent field strength contributions at point P

images:

$$\left. \begin{aligned} E_1 &= I_1 Z_{11} + I_2 Z_{12} + I_3 Z_{13} + I_4 Z_{14} \\ E_2 &= I_1 Z_{12} + I_2 Z_{22} + I_3 Z_{23} + I_4 Z_{24} \\ E_3 &= I_1 Z_{13} + I_2 Z_{23} + I_3 Z_{33} + I_4 Z_{34} \\ E_4 &= I_1 Z_{14} + I_2 Z_{24} + I_3 Z_{34} + I_4 Z_{44} \end{aligned} \right\} \dots \dots \dots (9)$$

The image currents are:

$$\left. \begin{aligned} I_3 &= -I_1 \\ I_4 &= -I_2 \end{aligned} \right\} \dots \dots \dots (10)$$

Substituting equations (8) and (10) in (9), we have:

$$\left. \begin{aligned} E_1 &= I_1 \left[Z_{11} + F(Z_{12} / \phi + \theta_{12}) - Z_{13} - F(Z_{14} / \phi + \theta_{14}) \right] \\ E_2 &= I_2 \left[\left(\frac{Z_{12}}{F} / -\phi + \theta_{12} \right) + Z_{22} - \left(\frac{Z_{23}}{F} / -\phi + \theta_{23} \right) - Z_{24} \right] \\ E_3 &= I_3 \left[-Z_{13} - F(Z_{23} / \phi + \theta_{23}) + Z_{33} + F(Z_{34} / \phi + \theta_{34}) \right] \\ E_4 &= I_4 \left[\left(\frac{Z_{14}}{F} / -\phi + \theta_{14} \right) - Z_{14} + \left(\frac{Z_{34}}{F} / -\phi + \theta_{34} \right) + Z_{44} \right] \end{aligned} \right\} \dots \dots \dots (11)$$

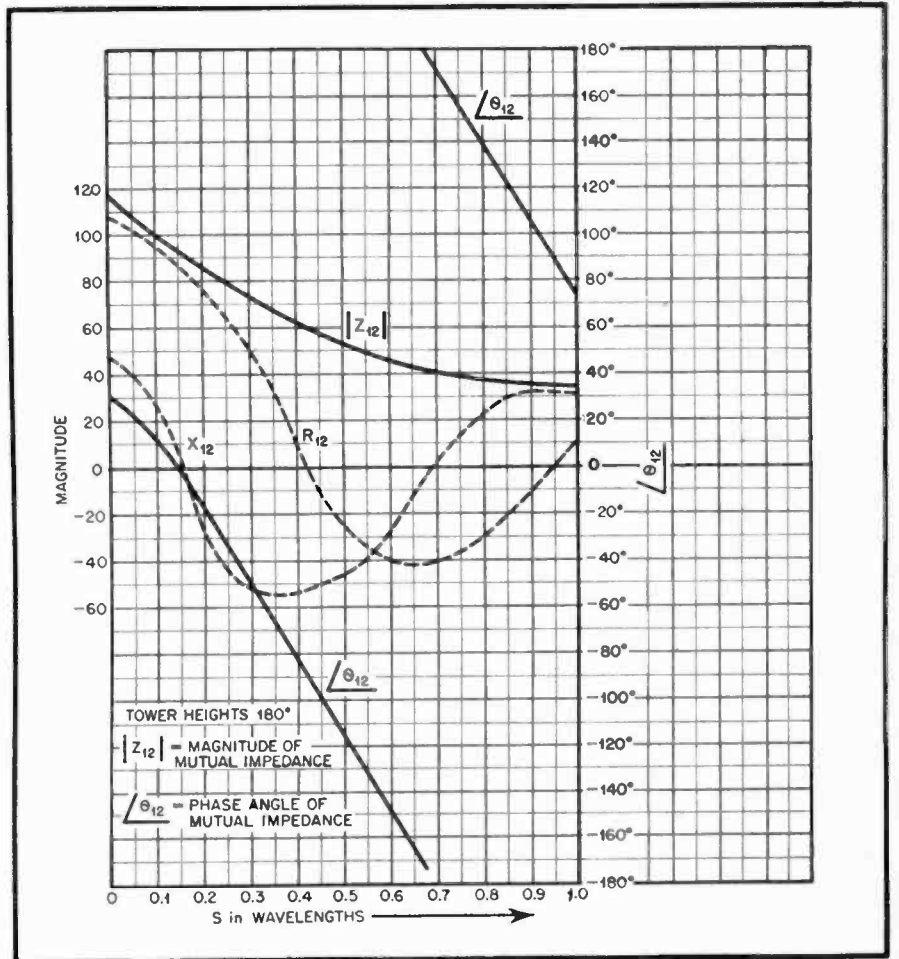

Fig. 9. Characteristics of mutual impedance of two-element array

where θ_{12}, θ_{23} etc. = phase angles of mutual impedances Z_{12}, Z_{23} etc.

In visualizing equation (11) the following relations must be kept in mind:

$$\left. \begin{aligned} Z_{11} \text{ etc.} &= R_{11} + jX_{11} \text{ etc.} \\ Z_{12} \text{ etc.} &= R_{12} + jX_{12} \text{ etc.} \\ R_{12} \text{ etc.} &= |Z| \cos \theta_{12} \text{ etc.} \\ X_{12} \text{ etc.} &= |Z| \sin \theta_{12} \text{ etc.} \end{aligned} \right\} \dots \dots (12)$$

Also, from the symmetry of the two elements and their images, we may conclude that:

$$\left. \begin{aligned} R_{11} = R_{22} = R_{33} = R_{44} \\ R_{12} = R_{34} \text{ and } R_{13} = R_{24} \text{ etc.} \end{aligned} \right\} \dots \dots (13)$$

Total Power

Each element has a power equal to $I^2 R$ where R is the resistive component of the element impedance as given under the relations in (12) and as discussed previously. P is the power input to the array 1 and 2; then, since an equal power exists in the image (assuming a perfect ground, which is permissible for this analysis, especially at broadcast frequencies) the total power input may be considered as $2P$. Thus, substituting from (13) and (12) in (11) and adding the powers of each element, we have:

$$2P = I_1^2 (2R_{11} - 2R_{13} + 2F^2 R_{11} - 2F^2 R_{13} + 4FR_{12} \cos \phi - 4FR_{14} \cos \phi)$$

and from the fundamental law

$$I = \sqrt{P/R}$$

the current in element 1 becomes:

$$I_1 = \sqrt{\frac{P}{(R_{11} - R_{13})(F^2 + 1) + 2F \cos \phi (R_{12} - R_{14})}} \dots \dots (14)$$

Equation (14) may then be used to find the current in each element when the resistive components are known, since the current relationships of all the elements are known. The field strength at point P of Fig. 10 at an azimuth angle ψ will be the vector sum of the currents in each element. Expressing the currents in terms of I_1 and performing the addition:

$$E = (K) I_1 \left[1 + \frac{(F/\phi + S^\circ \cos \psi)}{(1/2H^\circ \sin \psi)} - \frac{(F/\phi + S^\circ \cos \psi + 2H^\circ \sin \psi)}{2} \right]$$

where (K) is the necessary constant involving the distance and frequency of operation, and

- S° = spacing in degrees
- H° = height in electrical degrees

Transmission Line Analogy

As is well known, the input impedance of a half-wave vertical radiator fed at the base is quite high, being of the order of 200 to 600 ohms. The relationship between the radiation resistance and the resistive component of the total antenna impedance might

prove somewhat confusing at first thought, even though we must refer the radiation resistance to the current loop. It is perhaps unfortunate that so many examples given in the literature assume the common center-fed doublet for theoretical discussion.

If we return to the transmission line analogy, however, as briefly mentioned before, we may arrive at a more complete picture of this relationship.

The impedance function as modified for vertical tower theory has been seen to be*

$$Z_o = 120 \log l/a \dots \dots (15)$$

l = height in feet
 a = radius at base

The above equation is applicable to an antenna of the general shape of Fig. 11-A. The equation for antenna 11-B is

$$Z_o = 120 \left(\log \frac{2l}{a} - 1 \right) \dots \dots (16)$$

and for 11-C is

$$Z_o = 120 \log 2l/a \dots \dots (17)$$

a = radius at maximum width

Antenna Radiation Theory

Carrying out our transmission line analogy to antenna radiation theory, we may see that the antenna function is equivalent to a transmission line of a certain Z_o that is terminated in a

certain impedance Z_R that is not equal to Z_o , and having resistive and reactive components such that $Z_R = R_R + jX_R$. Thus reflection occurs on the line, and at the same time a certain amount of power is transferred to Z_R which is the load of free space as seen by the end of the antenna. It is possible then by use of the Compensation Theorem to terminate the transmission line in Z_o and replace the difference in impedance by a generator. We then have the equivalent circuit of Fig. 12.

By the Superposition Theorem the generators at the sending end considered by themselves will produce a voltage at an arbitrary point down the line such as ab , of $Ae^{-r'l}$, thus showing that this voltage will decrease as the distance down the line increases. The voltage caused by E_R , the generator at the receiving end (denoting the reflection on the line), will cause a voltage across ab of $Be^{+r'l}$, showing that this voltage will increase as the receiving end is approached. Therefore, the voltage at ab is

$$E_{ab} = Ae^{-r'l} + B e^{+r'l}$$

Similarly, the currents will have the relationship

$$I_{a \text{ or } b} = Ce^{-r'l} + D e^{+r'l}$$

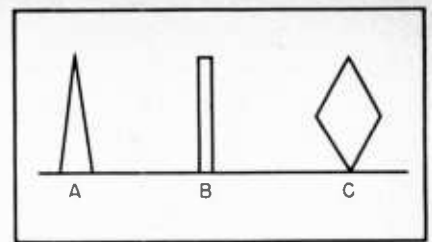

Fig. 11. Shapes of transmitting antennas

It is obvious that the first point of minimum current occurs close to the sending generator where the reflected current is small, and the principal current is also small (corresponding with the current node in the "voltage-fed" antenna). The first maximum point is farther away, where, although the secondary current is larger, the principal current is also large and the effective current is at a maximum (see graph of current relations in Fig. 12.)

End Effect

It must be remembered that as the energy of the principal wave is transferred to the boundary sphere, it must thenceforth travel in different modes of transmission. Therefore, along with the normal reflection of the principal wave, secondary waves in the boundary sphere adjacent to the antenna will generate reflected waves to match those in the field. In this manner, it is possible to visualize the so-called "end effect" of the antenna. This end effect then is seen to consist of "radiation" and a "reactive field."

If we find the ratio I_{min}/I_{max} of the first minimum amplitude to the first maximum amplitude, we find that

[Continued on page 52]

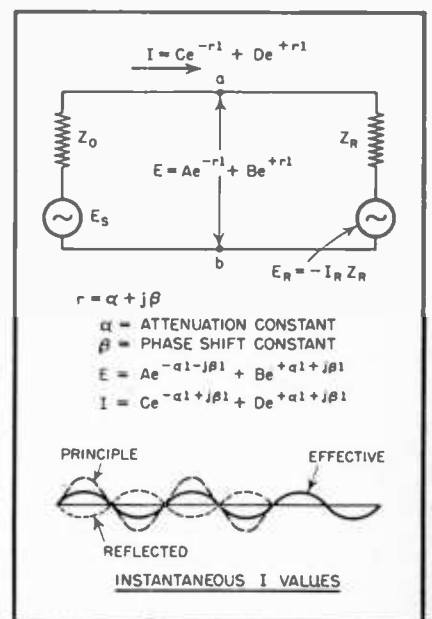

Fig. 12. Antenna current relations

* S. A. Schelkunoff: "Theory of Antennas of Arbitrary Size and Shape," IRE Proceedings, Sept., 1941.

HETERODYNE FREQUENCY METER

FOR some time, a very definite need for accurate, reliable, and completely portable frequency measuring equipment has existed. Mobile relay transmitters, emergency portable mobile equipment, as well as high-frequency relay (link) stations, are all required to maintain an accurate check on their operating frequency. With these needs in mind, the heterodyne frequency meter to be described has been developed. This equipment features unusual frequency stability under adverse conditions of vibration, temperature and humidity and may be easily, quickly and accurately recalibrated while in the field.

The Type SR-90 Heterodyne Frequency Meter is a completely self-contained instrument designed to facilitate the measurement of unknown radio frequencies falling within the range of 1 to 60 megacycles, these measurements being accomplished with an accuracy of .002% or better. The power supply consists of two 45-volt B batteries and four 1½-volt A batteries which are contained in the case.

Oscillator Design

The variable frequency oscillator employed in this equipment is a high stability device, tuning over a fundamental frequency range of from one to two mc. A type 6K8GT tube is used in an electron-coupled ultra-audion circuit, the output of which is rich in use-

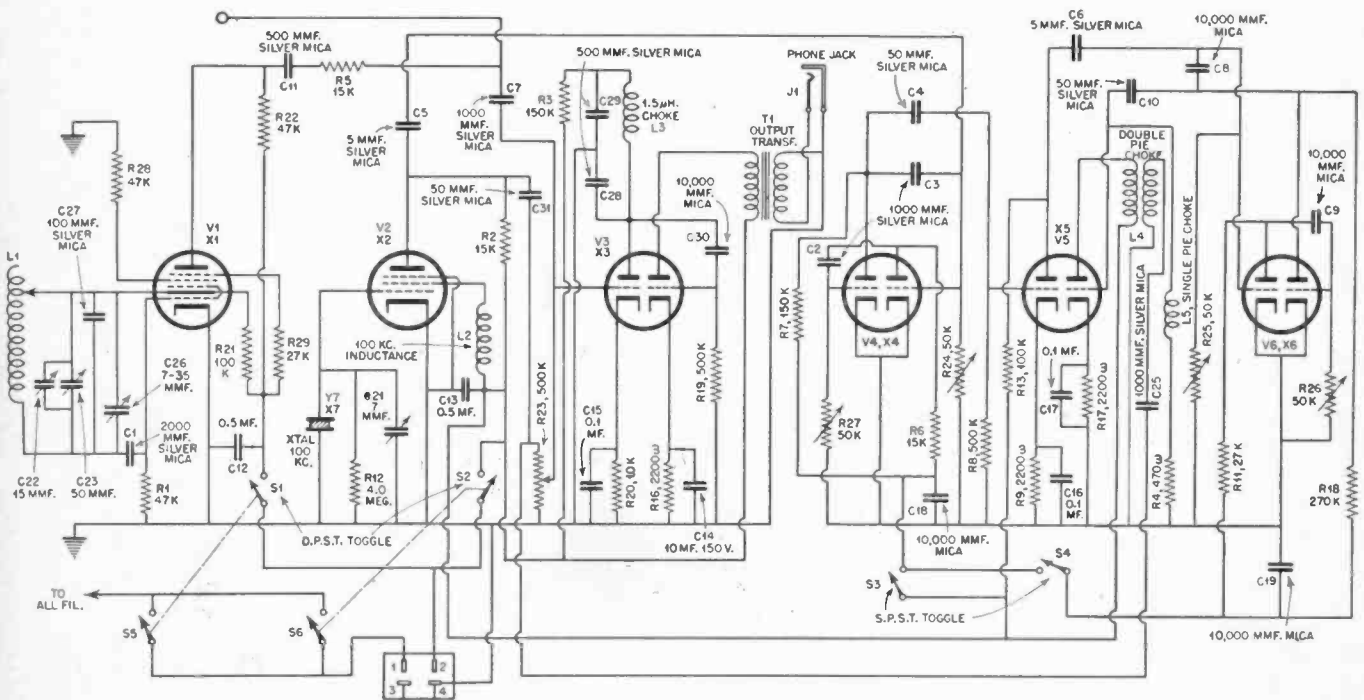

Fig. 1. Schematic diagram of heterodyne frequency meter. Tube types are given in text

ALBERT H. CARR

Chief Engineer, Fada Radio
and Electric Co., Inc.

Design data, constructional features, and applications of a highly precise frequency meter

ful harmonics. Harmonics up to the thirtieth are employed in extending the frequency range of the instrument to 60 mc.

The frequency-determining element of this oscillator consists of an inductor (see Fig. 1) wound with silver-plated Nilvar wire on a threaded and glazed ceramic form of very rugged construction. Both the wire and the form employed have practically zero temperature coefficient, which results in a very high order of frequency stability vs. temperature.

This inductor is rotated directly by the main tuning dial, which is divided into two hundred divisions over an arc of 360 degrees. In conjunction with an 0-10 division decimal indicator, this arrangement permits direct reading to an accuracy of one part in two thousand. To cover the range of from 1 to 2 mc, this dial must be turned through seventy complete revolutions. Each revolution is indicated on a consecutively numbered dial which is located behind the front panel. Only the figures indicating the actual number of variable inductor turns in use are visible to the operator through a window in the panel above the main dial.

The capacitive element of this oscillator circuit is provided in three forms. The main element consists of a 100 $\mu\mu\text{f}$ silver-plated-on-mica capacitor, C-27, of substantially zero temperature coefficient. This capacitor is located at the lower left hand side of the vari-

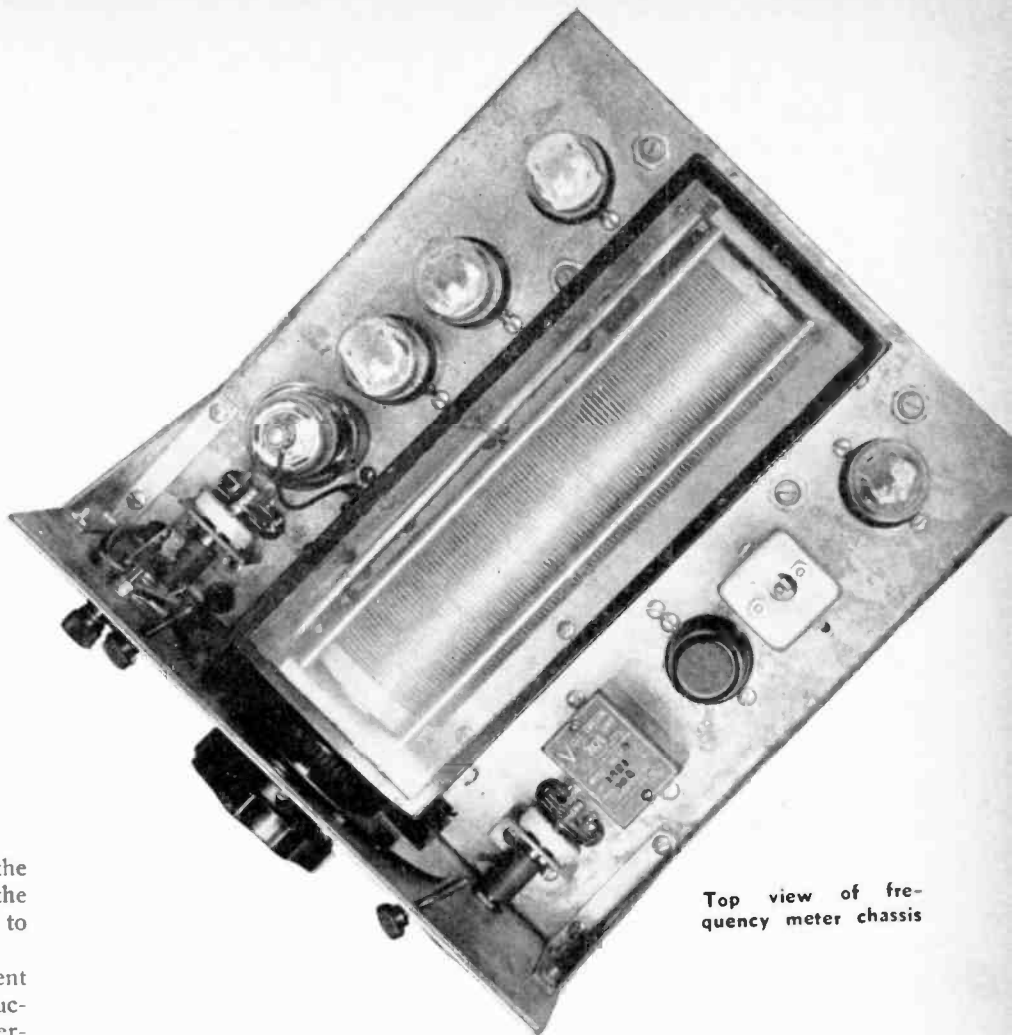

Top view of frequency meter chassis

able inductor in order that it may be subjected to substantially the same temperature variations as the inductor itself. Physically, immediately forward of this capacitor is located an adjustable ceramic capacitor, C-26, whose characteristics are such that its temperature coefficient is negative. Located toward the front of the chassis and below it, is a variable air trimmer capacitor, C-23, of 50 $\mu\mu\text{f}$ capacity. This unit has a positive temperature coefficient, and by use of the proper proportion of this and of the adjustable ceramic capacitor, any required coefficient of temperature compensation may be obtained with the proper total value of capacity in the circuit. Finally there is provided on the front panel a variable air capacitor, C-22, of approximately 5 $\mu\mu\text{f}$ capacity which is employed to "zero-set" the variable frequency oscillator. This small capacitor provides the means by which the variable frequency oscillator may always be set to a definite frequency for a given dial indication.

For calibration purposes, a quartz crystal oscillator of very high stability is employed. This oscillator employs one type 6SS7 tube in a conventional

circuit. The crystal employed is an RCA Type VC-5, whose drift is less than ten cycles total over the temperature range of -24 to $+70$ degrees C. This oscillator has a fundamental frequency of 100 kc. Proper utilization of its harmonics permits calibration of the variable frequency at intervals of 100 kc over its fundamental frequency range of 1 to 2 megacycles.

Provision is made for bringing the crystal oscillator frequency to exactly 100 kc by means of a "zero-set" control, C-21, located on the front panel. A suitable harmonic of the 100-kc oscillator may be selected to beat against a primary standard of frequency, such as WWV, and the former brought to exactly zero beat with WWV by adjustment of C-21, which is a small variable capacitor connected directly across the 100-kc crystal to provide a tuning range of approximately plus or minus 200 cycles, which is more than sufficient in view of the very low drift of this type of crystal.

The Multivibrators

Directly coupled to the 100-kc oscillator is a 6SL7GT dual triode employed as a 10 kc multivibrator, V-4,

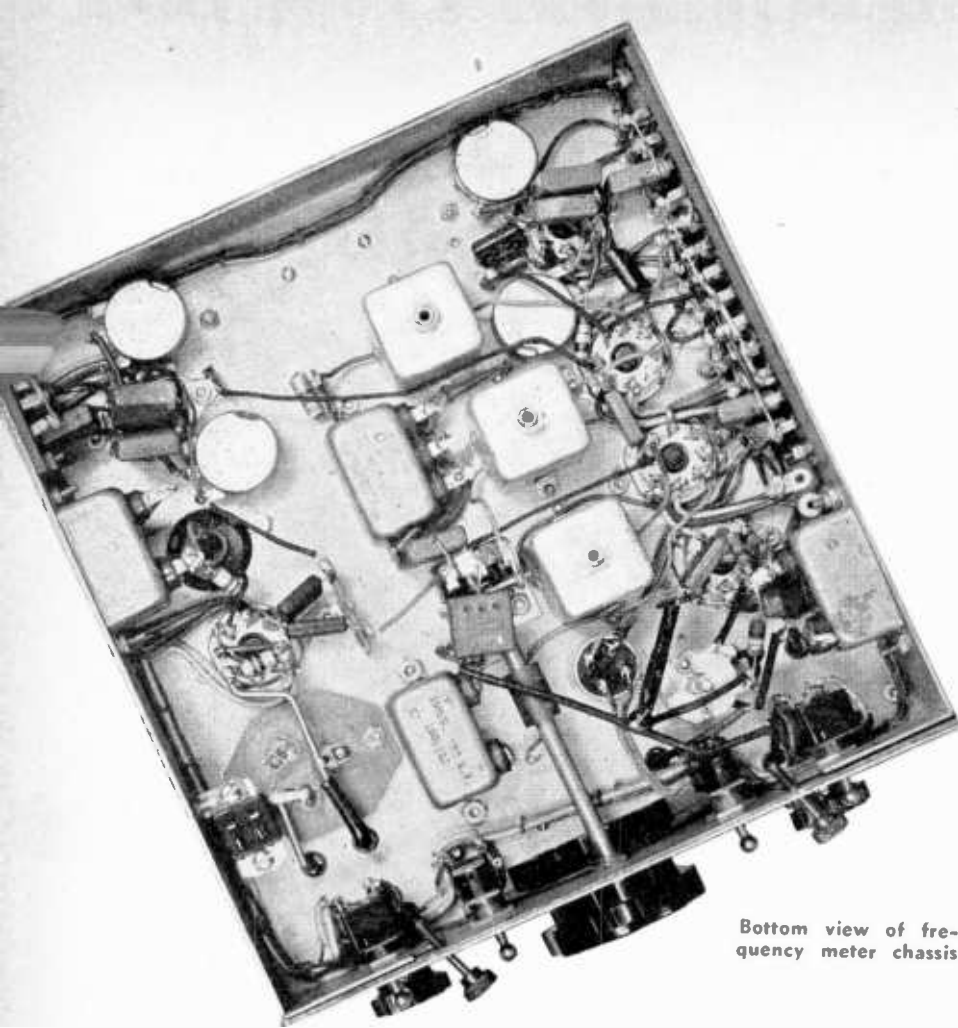

Bottom view of frequency meter chassis

whose frequency is controlled by the crystal oscillator. The 10 kc multivibrator is followed by an isolation amplifier, V-5 left, which in turn is followed by a 1-ke multivibrator, V-6. The output of the 1 kc multivibrator is fed into a harmonic amplifier, V-5 right, which is peaked for maximum response over the range of 1 to 2 megacycles. The use of the amplifier, V-5, increases the harmonic voltage output of the multivibrators to a point sufficient to allow calibration of the variable frequency oscillator at intervals of 10 or of 1 kc in the range of 1 to 2 mc. The multivibrators may be used only in conjunction with the crystal oscillator inasmuch as their frequency is directly controlled by it. By a suitable switching arrangement the calibration intervals for the variable-frequency oscillator become progressively 100, 10 or 1 kc, and by means of curves provided the frequency of any signal, the harmonics, fundamental or sub-harmonics that fall between these points can be very accurately determined.

The 10-ke multivibrator is directly connected to the 100-ke oscillator and, when in proper adjustment, its frequency of oscillation is completely con-

trolled by the 100-ke oscillator. A small amount of the output of the 100-ke oscillator is fed into the grid circuit of the first multivibrator section by coupling condenser C-5. It is possible to control the frequency of oscillation of the multivibrator by several methods, such as variation of the excitation voltage, variation of the capacitive elements of the circuit and variation of the resistive elements.

Inasmuch as the frequency of oscillation is determined by the time constant of the resistive and capacitive elements of the multivibrator circuit, variation of any of these would accomplish the same purpose. Variation of the resistive elements of the grid circuits was selected for this equipment because of its relative simplicity and stability. Two controls are provided, both located at the rear right-hand side of the chassis immediately adjacent to the dust cover. Their resistance is decreased as they are rotated in a counter-clockwise direction. These controls should be kept at similar settings; i. e., each should have approximately the same value of resistance in the circuit as determined by degree of rotation.

A fourth 6SL7GT dual triode tube,

V-3, is employed as a combination mixer and a-f amplifier. A portion of the output of both the variable frequency oscillator and the crystal oscillator-multivibrator "string" is fed into this mixer-amplifier at the proper level to obtain a suitable mix. With care it is possible to beat these signals to a frequency difference of less than one cycle per second.

The output voltage is varied by means of the gain control located directly below the main tuning dial on the front panel. Suitable curves are supplied with the instrument to allow rapid and accurate check of calibration accuracy.

Calibration

The following procedure is indicated to correctly calibrate this equipment:

The calibrating oscillator and the variable frequency oscillator should be turned on and allowed to warm up for a period of 30 minutes. Assuming the variable frequency oscillator to be set to 1000 kc, as the tuning dial is advanced another beat note will be heard as the 11th harmonic of the crystal is approached. This note should be carefully set to zero beat and its dial setting checked for accuracy. The 10-ke multivibrator should be turned on and a 10,000 cycle audio note should be weakly heard in the phones. The main tuning dial should be carefully returned over the range between the setting where the 11th harmonic of the crystal was determined and the point where the 10th (1000-ke) harmonic was located. At every 10-ke interval there should now be heard a harmonic of the 10-ke multivibrator. This multivibrator is in proper adjustment (i. e., adjusted to exactly 10 kc) when it is possible to count nine beat notes between each and every harmonic of the 100-ke oscillator. In the event that either more or less than nine beat notes occupy this space, adjustment of the multivibrator compensating controls is indicated.

In case there are more than nine 10-ke harmonics present it is an indication that the frequency of multivibrator oscillation is too high, i. e., the resistive-capacity combination is charging and discharging too rapidly. Therefore an increase in the amount of resistance in the frequency-determining circuit is indicated. By turning one of the multivibrator adjustments slightly to the right (clockwise) an abrupt change in the tone of the beat note should be heard, indicating that the frequency of oscillation has changed.

The aforementioned procedure of counting the beats between adjacent 100-ke harmonics should again be tried. If further adjustment in the

same direction is indicated, the other resistor should be varied until another change is heard in the tone of the note. By varying first one and then the other of the resistors, it should be possible to keep their value approximately the same, which is the desired condition. If the frequency of oscillation is too low, i. e., there are less than nine beats between 100-ke harmonics, the resistance should be varied in counter-clockwise direction.

If, by mishandling, the resistances become turned too far in the counter-clockwise direction, the multivibrator will become inoperative. The controls should be returned to a position approximating 50% of their rotation, and adjustments attempted again.

The procedure for determining the calibration of the 1-ke multivibrator is somewhat different from that outlined above inasmuch as the 1000-cycle tone generated by this unit is of much greater apparent intensity than that generated by the 10-ke multivibrator, requiring much greater care to accurately determine the actual point of zero beat. As zero beat is approached with the 1-ke multivibrator turned on, a flutter will be noticed in its tone and as the frequency difference becomes less, the beat difference may be counted. Perfect resonance is indicated by the "flutter" entirely disappearing. At this point the 1000-cycle tone becomes clear and steady, but flutters again if the dial is rotated further. In order to check the calibration of the 1-ke multivibrator, it is necessary to count nine of these resonance points between each of the 10-ke resonance points previously determined by the 10-ke multivibrator.

The procedure in adjusting the 1-ke multivibrator is similar to that stated heretofore except in certain details. Instead of counting the beat notes existing between adjacent 100-ke harmonics, it is necessary to count those existing between adjacent 10-ke harmonics. Two variable resistances are also provided for adjusting this multivibrator.

It should be remembered that when the 1-ke stage is turned on that there will be present in the phones a 1000-cycle note of strong intensity. This note is present at all times that the 1-ke stage is in operation and it is necessary to use care to detect the variation in it that is indicative of approaching zero-beat condition. Likewise more care is necessary in adjusting this stage because of the close proximity of one beat to another.

The variable frequency oscillator calibration may now be checked at any point on the dial (which is a multiple of 1 ke) against the calibration curve.

Operation

Assuming that the required thirty minutes of warm-up time have elapsed, the following procedure is recommended:

A radio receiver capable of tuning to 5 megacycles should be tuned to WWV and this station carefully tuned in. Loosely couple the output post of the equipment to the antenna terminal of the receiver by means of an insulated unit having one end fastened to the output post and its free end wrapped around the receiver antenna lead-in for a few inches. Feed the output of the crystal calibration oscillator into the receiver. There should be little if any frequency difference between the 50th harmonic of this oscillator and WWV. By tuning this frequency difference may be brought to absolute zero. It is desirable to observe the beat for several minutes in order to be sure that absolute zero frequency beat has been obtained, following which the radio receiver should be disconnected. The 100-ke oscillator is then tuned to exactly 100 ke. This oscillator, if not subjected to rough handling, will maintain its calibration over long periods of time.

The variable frequency oscillator may now be turned on, and inasmuch as its filament has been lighted during the initial warm-up period, as well as during the period when the 100-ke oscillator was being adjusted, it should be stable. The variable frequency oscillator should be tuned to approximately 1000 ke, as determined by the calibration chart supplied. As this dial setting is approached, a beat note should be heard in the phones. This will be the beat between the variable frequency oscillator and the 10th har-

monic of the crystal calibration oscillator. When the dial is tuned to the proper position as indicated by the calibration curve, the beat note may be brought to exactly zero by means of the control located on the front panel. Zero setting adjustment having established the variable frequency oscillator at exactly 1000 ke., rotate the dial to the reading corresponding to 2000 ke. Zero beat should be observed.

Measuring Frequency

In order to determine the frequency of an unknown signal being received, the following procedure is indicated:

The unknown signal is accurately tuned in on a radio receiver. Preferably this receiver should be of the type that employs a resonance indicating device such as an "S" meter of a "Magic Eye." The "S" meter type is to be preferred for this use inasmuch as a much more accurate determination of exact resonance is possible with it.

The output of the frequency meter is now fed into the antenna, the variable frequency oscillator tuned to close to zero beat with the signal to be measured, as indicated by the receiver, and the gain knob of the SR-90 adjusted its signal is approximately the same strength as the received signal. The most satisfactory "mix" will be obtained when these signals are of equal strength. As zero beat between the incoming signal and the variable frequency oscillator is now approached, it will be possible to count the beat difference between the two signals directly on the receiver's S-meter or "Magic Eye."

In the event that it is necessary to use a radio receiver for this purpose that is not equipped with an indicating device

[Continued on page 68]



Complete heterodyne frequency meter, ready for operation

Characteristics of RADIO WIRE AND CABLE

J. M. CALLER

Engineer, Sperry Gyroscope Company

A comprehensive survey of the various types of wire and cable used in radio equipment, with analyses and sound, practical information regarding their selection to meet specified service conditions

Magnet Wires

There are two general classes of magnet wire insulations, enamel films and textile wraps, used both singly and in combination. Enamel films may be subdivided into two types: (1) Oil-base enamel, much akin to varnish, applied by dip coating, and (2) synthetic enamel, a formal acetal resin commonly known as "Formex" or "Formvar," applied by extrusion. Textile wraps are utilized in several materials of which the most popular are cotton, silk (now largely supplanted by nylon), glass, and asbestos. Magnet wires are manufactured in A.W.G. sizes ranging from #4/0 to #46 inclusive but are restricted by NEMA⁵ Standards, which govern the entire industry, to the range of #8 to #40 inclusive.

Both types of enamel film are organic in nature and as noted heretofore are considered as A.I.E.E. Class A insulations subject to a maximum operating temperature of 105°C. (221°F.). The oil-base type is reddish-black in color and produced in two thicknesses known as "single" and "heavy" respectively. In the synthetic type, the natural film is clear translucent, imparting a deep orange shade to the insulated wire. The latter is also made regularly in two colored varieties, green and yellow, and in four thicknesses known as "single," "heavy," "triple," and "quadruple," respectively. Synthetic enamel is superior to the oil-base type in every respect, is in far greater demand today, and will probably entirely supplant the latter in the near future. For the present, however, "oil-base" is considered safer in the "single" thickness form since the dip-coating method of application provides a more uniform film than the extrusion process.

PART 2

The various textiles used for magnet wire insulation fall within all three A.I.E.E. standard classes (O, A, or B) depending upon the material and the impregnation. Cotton, silk and nylon being organic materials are rated as Class O if untreated, with a temperature limit of 90° C. (194° F.), or as Class A after impregnation. Glass and asbestos insulations are inorganic in nature and, when impregnated with an organic binder, are rated as Class B for operation at temperatures up to 130° C. (266° F.).

Selection:— It would appear from the foregoing that greatest economy should be realized in design through the use of Class B insulation because of their higher permissible operating temperature. This is by no means true, since the insulation thickness is of far more importance. Differences in thickness of less than 0.001 inch in the wire insulation will often amount to considerable volumetric differences in the finished coil. The larger the coil, the larger the machine; and the larger the machine, the greater the weight and cost. Reduction of weight and size to the absolute minimum compatible with good design practice is very important in most applications, particularly so for equipment destined for installation in aircraft.

Unfortunately, the magnet wire insulations that provide the least build-up of diameter are Class A materials. These are the enamel films which in general are much thinner than any form of textile insulation, but included

among the textiles are the only Class B materials available—glass and asbestos. Obviously, then, the most economical design can be obtained only by careful and judicious balancing of winding space factors against operating temperature, choosing that insulation which, in the desired gauge size, results in the smallest finished coil. A chart of space factors for the various types of magnet wires in A.W.G. sizes from #8 to #40 inclusive, based upon a square lay, is shown in Fig. 5.

There are several other factors which should be given consideration in selecting the type of magnet wire insulation best suited for any specific application. Of these, the most important are dielectric strength, toughness or abrasion resistance, flexibility, stability under pressure and vibration at elevated temperatures, and imperviousness to the solvents used in impregnating varnishes. The relative importance of such factors will depend upon the application and will not be discussed here since adequate information is available from commercial catalogs and bulletins published by the various manufacturers. An excellent treatise on the subject, with particular emphasis on synthetic enamel and including an extensive list of references, will be found in a technical paper by Patnode, Flynn and Weh.⁶

Impregnation:— Magnet wire coils should always be thoroughly impregnated with a good quality insulating varnish, prior to assembly, for the following reasons:

1. To remove all traces of occluded moisture and thereby eliminate the most potent cause of corrosion leading to eventual failure in service.

2. To fill all interstices of the coil

with a solid dielectric and thereby seal the winding against re-entrance of moisture.

3. To bond the winding into an integral unit and thereby prevent relative movement between individual turns or layers in operational service.

Impregnation may be accomplished by any of three methods—dipping, centrifugal force, or vacuum pressure. Dipping is the simplest process but less effective than the others with respect to both dehydration and penetration.

Coils to be impregnated by dipping are first preheated for a period of one to four hours, depending on the size and shape, to expel internal moisture. The preheating temperature must be carefully controlled between 100° C. (212° F.), the boiling point of water, and 105° C. (221° F.), the softening point of enamel films. After preheating, the coils are immersed while still hot in the insulating varnish and left there until all bubbling ceases or preferably longer. They are then removed, allowed to drain in air, and baked at the recommended high temperature in a well-ventilated oven until complete curing of the varnish is effected.

An improvement over the dipping method is obtained by the centrifugal process in which the coils are rotated at high speed while immersed in the liquid varnish. The centrifugal forces so developed tend to force the varnish into the windings to a greater depth than occurs by simple immersion, rivaling that afforded by vacuum impregnation. In addition, much less time is required for this process since the whirling motion accelerates the speed of penetration and provides subsequent drainage of the coils after the varnish is pumped from the immersion tank. Preheating and final baking are the same as for the straight dipping process.

Impregnation by vacuum pressure is recognized as the best method now available. Excellent dehydration is achieved by first evacuating the impregnation chamber and then admitting the varnish to the chamber under vacuum pressure. The preheating can be performed either before or during the evacuation cycle, depending upon the type of equipment employed. If done simultaneously, however, the chamber must be cooled before varnish is allowed to enter. After impregnation, the coils are drained and baked as described above.

There are two general types of insulating varnishes in use today: (1) Natural or oleoresinous; and (2) synthetic resinous. The first type, which is much the older, dries slowly from the surface at temperatures up to about 110° C. (230° F.), whereas the

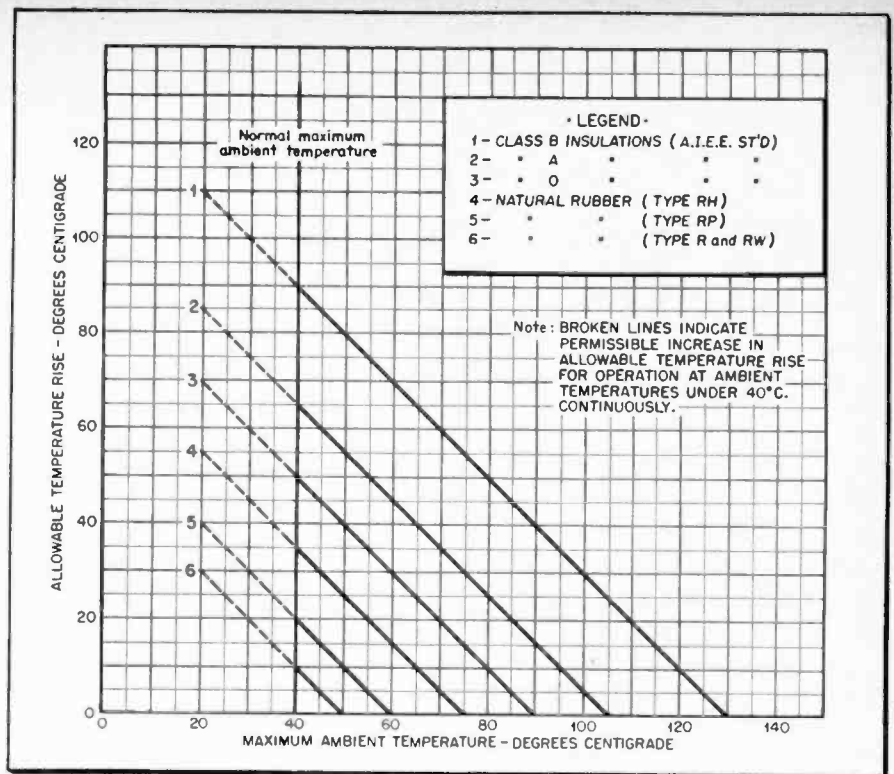

Fig. 1. Allowable temperature rise for various insulations. Curve 4 applies also to neoprene or buna S, and plastic elastomers, Vinylite V or Koroseal with textile wrap or braid. Curve 5 also covers Vinylite V or Koroseal. Natural rubber is N. E. Code. (Reprinted from May issue)

second type solidifies rapidly from within at temperatures up to about 135° C. (275° F.). As pointed out by G. J. Hepp,⁷ substantial improvements in performance are possible with the internal drying varnishes in many applications. The ultimate impregnant, however, is yet to be developed. It must have temperature stability consistent with that of inorganic materials such as asbestos and fiber glass so that a new high-temperature rating² for electric equipment can be established. Higher permissible operating temperature would of course mean substantial reductions in the size and weight of machines and much effort is being directed toward this end. Definite progress is reported in a recent technical paper by O. Kiltie⁸ on the design of aircraft transformers capable of operating at 225° C. (437° F.).

Litz Wires

Construction:—Coils for use in radio and allied circuits operating at frequencies in the conventional broadcast and short-wave spectrum are often made of Litz wire. This type, sometimes called "Litzendraht," differs from regular magnet wire in that the conductor consists of a number of strands each individually insulated to increase the effective surface area. The finer the stranding, the larger the effective surface area and the smaller the increase in resistance at high fre-

quency due to "skin-effect." Modern Litz wires utilize enameled strands laid up either parallel or twisted and covered with a serving of cotton, silk, or nylon textile.

Selection:—The choice of an appropriate Litz wire for a given application by mathematical methods alone is complex and unreliable at best. Experience in the art of coil design has proven much more satisfactory. Out of over 100 different types of stranding construction that have been developed, not more than 15 to 20 are used to any extent today. The theory nevertheless is interesting and has been given by Butterworth⁹ and amplified by Beattie¹⁰ through the use of nomograms (abacs).

Lead Wires

Construction:—Flexible leads from the magnet wire coils of any electrical component to soldering terminals thereon or brought through the case for external connection are called lead wires. Such wires usually have fine-stranded conductors, for reasons of flexibility, in A.W.G. sizes from #14 to #22 or smaller. The insulations employed thereon vary widely, depending upon the application, from simple textile servings or feltings of cotton, silk, or asbestos as on magnet wires to combination forms of rubber (natural or synthetic) and textile braids in different colors as on radio hook-up wires.

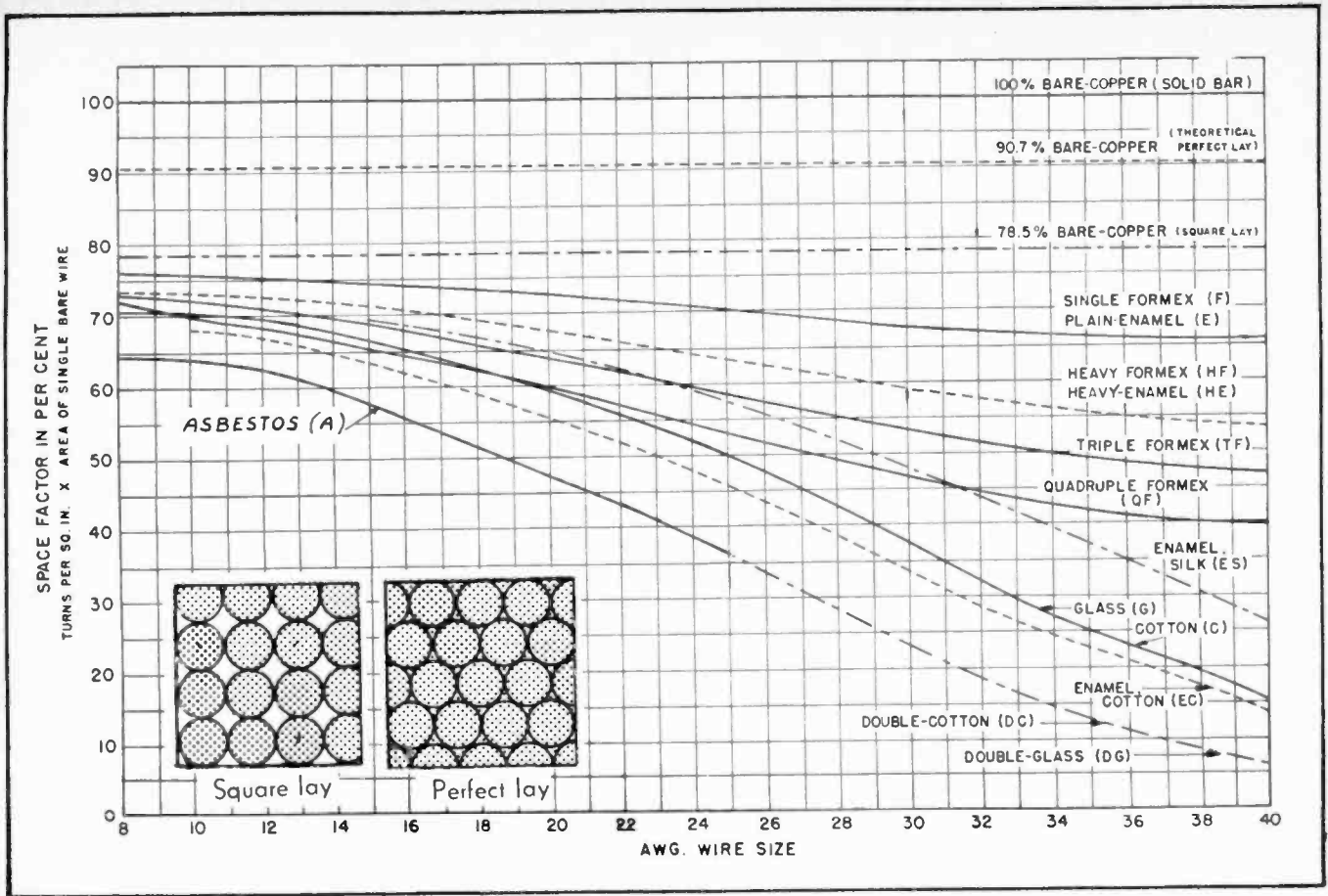

Fig. 5. Space factor in per cent for various wires and insulations, using square or perfect lays. Courtesy of General Electric Company

Selection:—Lead wires may be divided into two classes with respect to service—internal and external. Internal leads must be primarily heat resistant to withstand the very high operating temperatures inside the frame or case of the machine. An extreme heat problem is found in transformer leads which must not disintegrate in contact with molten potting compounds and waxes poured at temperatures of 400° to 500° F. For such purposes, inorganic insulations such as impregnated felted asbestos or treated fiber glass braiding will be found most satisfactory.

External lead wires do not require such extreme heat resistance but must be very flexible, non-inflammable, and highly resistant to abrasion, crushing, oil vapors, fungus growth, and vermin. Protracted exposure to sunlight and adverse weather conditions must not promote deterioration or obliterate the colors or other coding employed. These requirements are best met, in low-voltage applications, with straight textile insulation such as cotton, silk, or nylon serving covered by an impregnated and lacquered cotton braid. For potentials higher than 30 volts, the textile under-serving should be replaced by an adequate primary insulation such as cellulose acetate butyrate tape, varnished cambric, or synthetic rubber compound.

Radio Hook-Up Wires

Construction:—All wiring used for interconnecting the various components in the radio chassis and for similar types of service is known as radio hook-up wire. Both stranded and solid conductors are used in A.W.G. sizes commonly ranging from #14 to #22. A recent and definite trend in the direction of smaller sizes down to #28 for aircraft radio instruments is apparent but these sizes are not yet widely manufactured. Aircraft power and lighting circuits, on the other hand, utilize larger sizes up to #4/0.

The different types of insulation which have been used on hook-up wires are legion. Natural rubber compounds in the various grades covered by the National Electric Code¹¹ have been predominant in this field for many years, however, because of their superior electrical and physical properties. In general, the higher the percentage of crude rubber or latex in the compound, the better the performance. Compounds with from 20 to 60 per cent of crude rubber have been commonly employed in both standard and heat-resistant grades.

Although rubber compounds possess high dielectric strength and insulation resistance, fairly low dielectric constant and power factor, and excellent

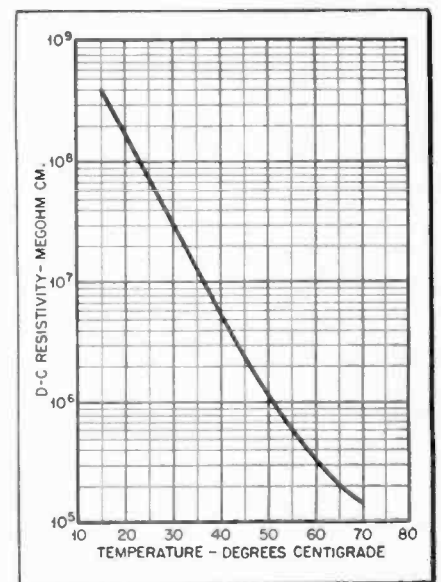

Fig. 6. Insulation resistance vs. temperature graph

tensile strength, elongation, and recovery, they do have definite limitations in other respects. The most serious of these are the lack of resistance to oils and the high rate of deterioration (aging) through exposure to heat, sunlight, and weather. Because of these factors, much effort has been directed in the last decade toward the development of synthetic, rubber-like materials.

Original attempts to create synthetic rubbers were logically based upon the chemical structure of the natural product but all materials of such character were found to be very inferior in performance. The method of attack then was shifted to find materials of other compositions having rubber-like properties. These efforts were richly rewarded first by the discovery of Neoprene (1933) and closely followed by the related materials Koroseal and Vinylite. Neoprene is much tougher than natural rubber and therefore is excellent for cable jackets but has very poor dielectric properties and so should not be used for primary insulation. Koroseal and Vinylite V are moderately good dielectrics and can be compounded to provide adequate toughness for jacketing service. All three are considerably superior to natural rubber with respect to imperviousness to oils, solvents, sunlight, and other detrimental influences.

Chemical research in this field has been greatly accelerated by the government synthetic rubber program brought about by the present conflict. Several new types have been discovered and are now being produced in huge or limited quantities as required to meet the needs of the Armed Forces. Each type has its particular niche of application and is equal or superior to natural rubber for the specific service intended. Although the use of these new materials is mandatory for the duration of the war, there is little doubt that they will continue to occupy important positions in peacetime production.

Rubber substitutes may be classified into two categories: (1) Synthetic rubbers, and (2) plastic elastomers. The first group includes the various types of thermosetting materials which require vulcanization by heat after application to the conductor in the same manner as natural rubber. In the second group are the thermoplastic materials which have elastic properties but otherwise bear little or no kinship to natural rubber. The compounds of both groups that are of importance to the wire and cable industry have been well described by E. D. Youmans¹² with respect to their chemistry, properties, and principal field of applica-

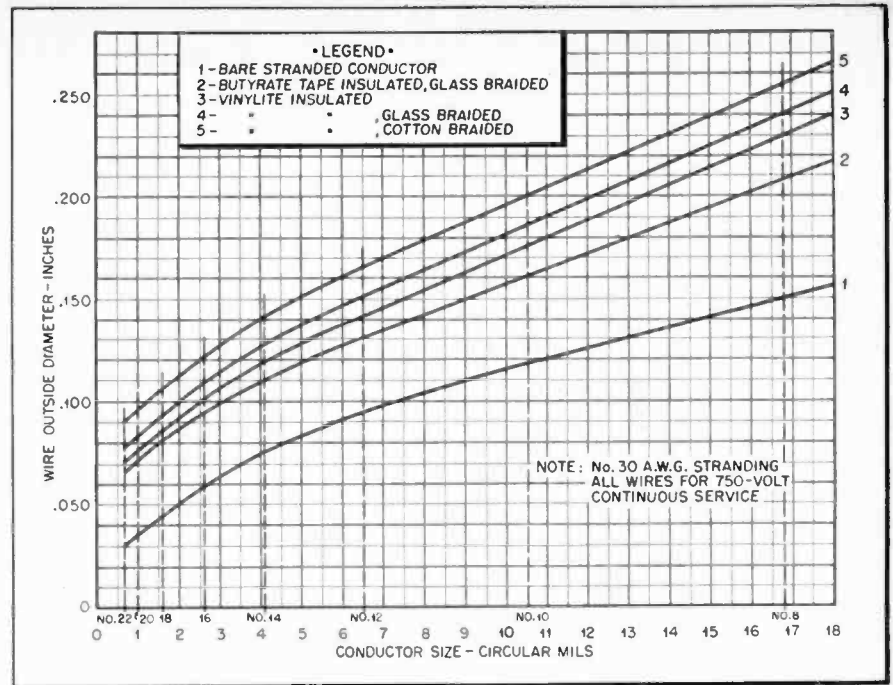

Fig. 7. Outside diameters of radio hook-up wires

tion. All of these materials are popularly known by trade names, the most common of which are given in Table 3.

In general, the compounds which are restricted to jacketing service will withstand severe usage but are poor electrically. Conversely, those listed for insulation service only are excellent dielectrics but relatively poor mechanically. Where both applications are shown, the compound may be regarded as intermediate, neither excellent nor poor in any important respect.

The primary insulation used on radio hook-up wire is ordinarily applied by extrusion. A single exception is Tenite II which, although also extrudable, is customarily applied in the

form of thin spiral tapes bonded together by heat. Extruded thermoplastic insulations such as Vinylite V and Koroseal are often used as the sole covering and are available in nine or ten colors for circuit identification. Tape insulated conductors must be covered by textile or otherwise protected to avoid unwrapping and other mechanical damage with ordinary usage.

Some hook-up wires are provided with a layer of inorganic insulation, such as impregnated felted asbestos, over the primary insulation to decrease the fire hazard. This secondary insulation is of doubtful advantage in electronic circuits and may even be

[Continued on page 64]

TABLE 3
RUBBER SUBSTITUTES

Trade Name	Chemical Formulation	Application
Synthetic Rubbers		
Neoprene	Polychloroprene	Jacketing only
Buna S (GRS)	Butadiene-Styrene Copolymer	Insulation and jacketing
Butyl Rubber	Isobutylene-Diolefin Copolymer	Insulation only
Thiokol	Organic Polysulfides	Jacketing only
Plastic Elastomers		
Koroseal	Polyvinyl Chloride	Insulation and jacketing
Vinylite V	Polyvinyl Chloride Acetate	Insulation and jacketing
Tenite II	Cellulose Acetate Butyrate	Insulation only
*Vistanex	Polyisobutylene	Insulation only
*Polythene	Polyethylene	Insulation only

* Restricted at present to high-frequency-applications by government allocation.

Factors Involved In CHOOSING TUBE TYPES

A. C. MATTHEWS

THE usual data characteristic chart published by the tube manufacturer is entirely inadequate for use by the design engineer. While the chart provides necessary information as to base diagrams, dimensions, characteristics under average operating conditions and absolute maximum or design center ratings, it does not show the effect of different load conditions, currents, or values of tube parameters under all operating conditions. These are of utmost importance to the design engineer. In some cases many tubes appear to be quite similar in the chart, yet in actual operation they are quite different, with one being definitely superior to the others for a specific application. An attempt will be made to point out some of these limitations and show how the desired information can be obtained from characteristic curves.

Plate Characteristic Curves

The "family" of plate characteristic curves is the most widely used presentation of tube characteristics, particularly for receiver tube applications. It should be pointed out at this time that characteristic curves represent only average results and therefore variations are likely to exist between tubes. It is desirable then to allow a margin of safety in the design to accommodate these expected variations. A typical plate "family" is shown in Fig. 1. The plate current is plotted against the plate voltage for a particular value of grid bias. Each curve therefore shows the plate current with a fixed grid bias at any desired plate potential. A series of such curves for

different grid potentials comprises the plate "family."

Now assume it is desired to operate the tube with a maximum plate potential of +250 volts. It will be found by inspection of the plate family that the point of zero plate current occurs with a grid bias of -16 volts. This is the cut-off bias and must be known, if it is desired to operate the tube as a Class B amplifier. (For Class C operation, two times cut-off bias is used). Note that the plate current cuts off fairly sharply with plate potentials less than +250 volts. Such information is not obtainable from a data sheet, and since it is important in determining the usefulness of a tube as an oscillator, the value of the curves are apparent. For good operation as an oscillator a sharp cut-off is desirable.

Because the amplification factor (μ), plate resistance (r_p), and the transconductance (G_m) are not constant over a wide range of operating voltages, it is desirable to determine their actual value at a particular operating point. This information is not ordinarily obtainable from a data chart, although it can be readily ascertained from the characteristic curves.

As an example of how to determine these parameters at a particular oper-

ating point, take the plate characteristic of the 7A4 triode, and assume the plate potential to be +250 and the grid bias -8 volts. A vertical line is drawn from the +250-volt point on the E_p axis. The intersection of this line with the -8 volt bias curve determines the operating point. The plate resistance can be found by drawing a line tangent (BC in Fig. 2) to the -8 volt bias curve so that it intersects the curve at point (A). Since the plate resistance is equal to the reciprocal of the slope of the characteristic curve, it is only

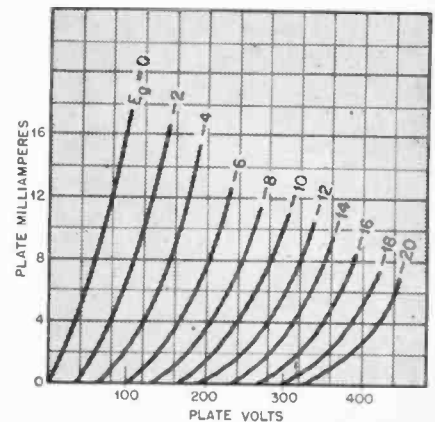

Fig. 1. Typical plate family, type 7A4

PART II

Practical considerations in the selection of proper vacuum-tube types for various applications are discussed

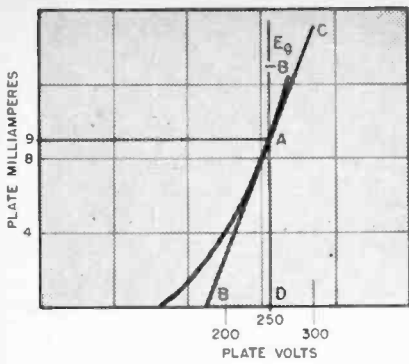

Fig. 2. Determination of plate resistance

necessary to divide the plate voltage change between points *BD* by the current change *AD* to determine its value for this particular operating point.

$$r_p = \frac{de_b}{di_b} = \frac{69 \text{ volts}}{.009 \text{ amp.}} = 7555 \text{ ohms}$$

It should be noted that the slope of the E_p - I_p curve is not constant; therefore, r_p will vary with changes in signal voltage if operation extends beyond the straight portion of the characteristic.

The amplification factor (μ) can be determined as shown in Fig. 3, by drawing a horizontal line *BC*, representing constant plate current, through the operating point *A*. Since μ is equal to the ratio of a change in plate voltage to a change in bias voltage for a given constant plate current, it is only necessary to draw vertical lines equally spaced on each side of point *A* to the E_p axis. The change in grid bias along *BC* divided into the change in plate potential as noted at *DE* is the μ of the tube.

$$\mu = \frac{de_b}{de_g} = \frac{80}{4} = 20$$

The transconductance (G_m) can also be determined from the plate family. By definition, G_m is equal to the change in plate current obtained with a change in grid voltage, while the plate potential remains constant. The line *BC* in Fig. 4 represents a constant plate potential through the operating point *A*. Now draw two horizontal lines intersecting the constant plate voltage line at equal distances on each side of the operating point (*A*), extending to the I_p axis. The change in plate current, *DE*, divided by the change in grid bias, *BC*, is equal to the G_m .

$$G_m = \frac{di_p}{de_g} = \frac{14.5 - 4.5}{4} = \frac{.010}{4} = 2500 \text{ ma/volt or micromhos.}$$

In the determination of the above parameters it is important to use points equidistant each side of the operating point in order to minimize errors due

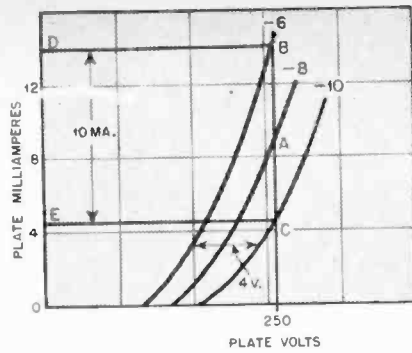

Fig. 3. Determination of amplification factor

to curvature of the plate characteristic. It should be remembered that the above curves assume no series resistance in the plate circuit.

Resistance Loads

Another useful function of the plate "family" is the determination of the correct bias for operation in resistance-coupled amplifiers. It is obvious that if a resistance load is employed in the plate circuit, the voltage at the plate will vary with changes in plate current due to the signal. Therefore, it is necessary to construct graphically a load line on the characteristic curve to obtain the correct operating point.

As an example, assume the maximum plate supply voltage to be +250 volts, and a resistance load of 100,000 ohms to be used. A line representing this load is drawn on the plate family by connecting a point at the maximum plate voltage (250) and zero plate current, with a point at zero plate voltage and a current equal to 2.5 ma. ($I = E/R$). This is shown in Fig. 5 as *AB*. A resistance-coupled amplifier is operated as Class A so no grid current is permitted. For this reason we draw a vertical line *CD* where the load line intersects the zero-bias curve. This establishes the point of lowest instantaneous plate voltage at 30 volts, and since the maximum is determined by the power supply, which is 250 volts, the average or operating point should be midway between the two, at

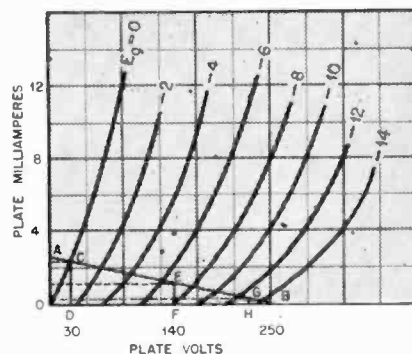

Fig. 5. Load line construction

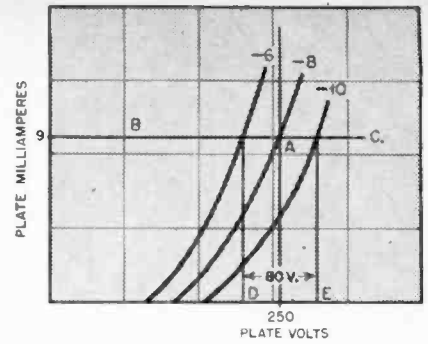

Fig. 4. Determination of transconductance

EF, which is 140 volts. Having obtained the operating point and noting that it lies on the plate current curve for -6.5 volts bias and that the plate current is 1.2 ma, it is then possible to use Ohm's law to calculate the bias resistor.

The vertical line *GH* which passes through the load line where it intersects the -13 volt curve (twice operating bias) establishes the maximum plate voltage swing, since a larger signal would exceed the operating bias and cause grid current to flow. The peak signal output will then be equivalent to one-half the difference between points *D* and *H* on the E_p axis.

Pentagrid Converters

In the design of equipment using a pentagrid converter tube the value of a curve showing conversion conductance vs. oscillator grid current is evident. Such information (Fig. 6) clearly shows the effect of oscillator strength on converter gain and is of great assistance to the designer.

The subject of tube characteristic curves can not be thoroughly covered without going into lengthy detail but it is hoped that the above examples have shown how characteristic curves can be much more reliable as a guide to tube operation than any data chart. Data charts do, however, save a lot of time in the preliminary selection of a tube type. The final choice, however, should always be made after a

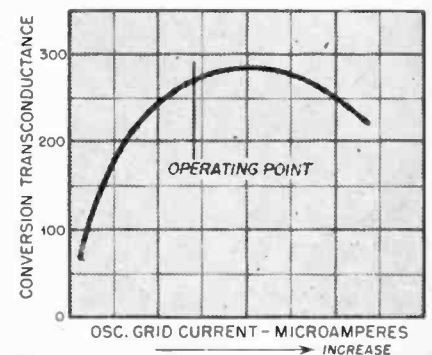

Fig. 6. Pentagrid converter characteristic

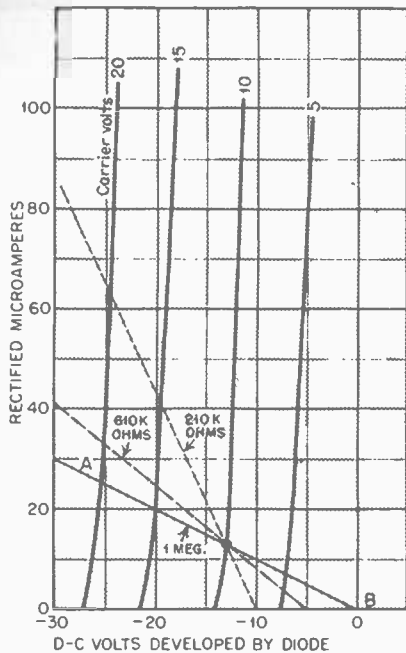

Fig. 7. Average characteristics of diode rectifier with load lines

a thorough study of the actual characteristic curves.

Diode Detectors

A family of average characteristics for a typical diode detector is shown in Fig. 7. Each curve is obtained by varying the d-c load resistance and measuring the diode current with a constant signal input voltage. Several values of input are used to complete the family. For purposes of illustrating how these curves are used in the design of a detector we will assume a load resistance of one megohm is to be employed. A load line (AB) having a slope representing the chosen value of resistance (1 megohm) is drawn on the family of curves as shown.

Starting at zero voltage and current as one point, the line extends to the left to -30 volts and 30 microamperes as the other point. (One megohm at 30 volts equals a current of 30 microamperes). Now suppose an unmodulated carrier voltage with an amplitude of 10 volts rms is impressed on the diode. This establishes the operating point at the intersection of the load line and the 10 volt curve. The d-c voltage resulting from the carrier is used for AVC purposes. When modulation is applied to the carrier particularly when the modulating frequency varies.

Fig. 8 shows a typical diode schematic. Here it can be seen that so far as audio frequencies are concerned the one-megohm load resistor is shunted by the avc, the diode condenser and the input circuit of the following audio stage. The fact that the circuit components are not all resistive makes the load impedance vary with frequency. A few simple calculations will show that the effective load impedance will vary from 610,000 to 210,000 ohms as the frequency is increased from 50 to 5000 cycles. These new values of load impedance are drawn as dotted lines in Fig. 7 and indicate the range over which the impedance will vary under the specified conditions. From these we can secure enough points to draw a curve showing the diode output as a function of carrier voltage input. See Fig. 9. Note that with the 210,000 ohm load (operation at 5000 cycles) the current is cut off with low signal inputs, causing distortion with a high-percentage modulated carrier.

From the above it should be possible to design a detector circuit which will have very little distortion.

Rectifiers

An ideal rectifier would be one which would present zero impedance to the current flow in one direction and infinite impedance in the opposite direction. While the high-vacuum tube does not entirely fulfill these requirements, it serves satisfactorily as a means for obtaining d-c voltages in receivers and small transmitters.

Half-wave rectifiers, when used singly, are generally confined to circuits where the current demands are relatively low. The output is direct-pulsating current with the frequency being the same as the a-c supply voltage. Full-wave rectifiers are more generally used where higher output currents are required and since the ripple frequency is twice that of the a-c supply voltage a smaller filter can be used to smooth the direct-pulsating current into d-c.

The maximum a-c voltage for rectifier tubes is generally given as an rms voltage at a specified current. The peak inverse voltage is also often given. For half-wave rectifiers, this is 1.41 times the rms voltage applied to the plate, while in a full-wave rectifier it is equal to 1.41 times the total rms secondary voltage (two times half-wave operation) minus the voltage drop in the conducting portion of the tube. The voltage drop is usually negligible in comparison to the secondary voltage.

The maximum peak plate current is dependent upon the type of filter employed. With a high-inductance choke input the peak current is only slightly greater than the average load current; but with a low-inductance choke or a high-capacity condenser input the peak current should be checked, since it is

[Continued on page 58]

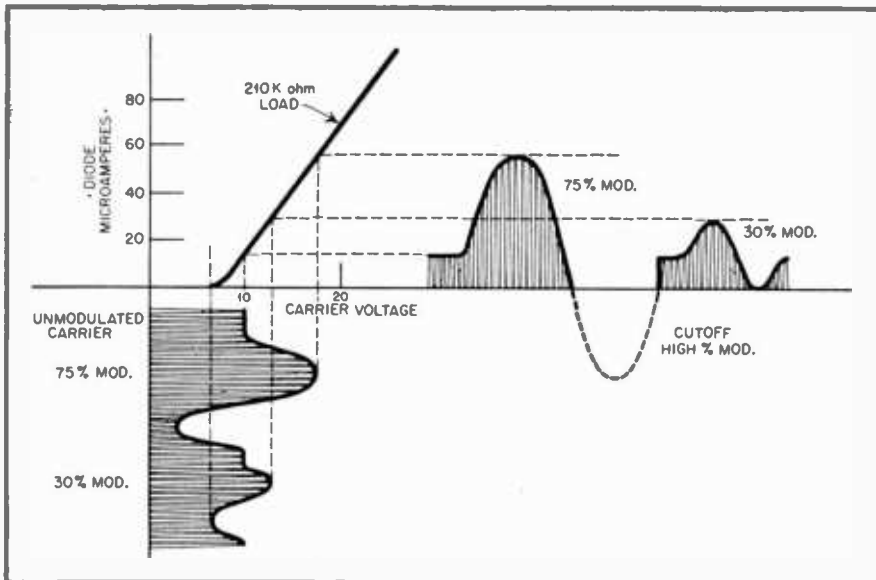

Fig. 9. Diode detector characteristic showing distortion with low signal input and high percentage modulation

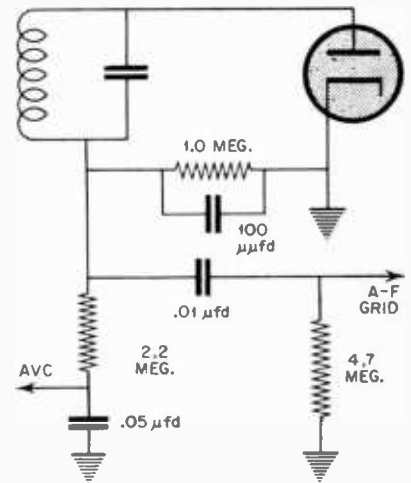

Fig. 8. Typical diode detector

RADIO DESIGN WORKSHEET

NO. 26—PHASE-MODULATED WAVES

★ The generalized expression for an alternating current is

$$e = A \cos (\omega t + \theta) \dots\dots\dots(1)$$

If this wave is modulated by a voltage

$$KA \cos pt \dots\dots\dots(2)$$

there results $e_1 = A \cos \omega t (1 + K \cos pt)$

Now, if θ in equation (1) were to be varied in accordance with the signal of equation (2) the result would be $e_2 = A \cos [\omega t + \theta (1 + K \cos pt)] \dots (3)$

Equation (3) by ordinary trigonometric transformations can be expanded to

$$e_2 = A \cos (\omega t + \theta) \cos (K\theta \cos pt) - A \sin (\omega t + \theta) \sin (K\theta \cos pt)$$

Expanding the cosine and sine terms in accordance with their power series

$$\cos \theta = 1 - \frac{\theta^2}{2} + \frac{\theta^4}{24} - \frac{\theta^6}{720} + \dots$$

$$\sin \theta = \theta - \frac{\theta^3}{6} + \frac{\theta^5}{120} - \frac{\theta^7}{2520} + \dots$$

yielding,

$$e_2 = A \cos (\omega t + \theta) - AK\theta \sin (\omega t + \theta) \cos pt - \frac{AK^2 \theta^2}{2} \cos (\omega t + \theta) \cos^2 pt + \frac{AK^2 \theta^2}{6} \sin (\omega t + \theta) \cos^2 pt + \dots$$

Now,

$$\sin (x+y) = \sin x \cos y + \cos x \sin y$$

$$\sin (x-y) = \sin x \cos y - \cos x \sin y$$

$$\sin x \cos y = \frac{1}{2} \sin (x+y) + \frac{1}{2} \sin (x-y)$$

$$\cos (x+y) = \cos x \cos y - \sin x \sin y$$

$$\cos (x-y) = \cos x \cos y + \sin x \sin y$$

$$\cos x \cos y = \frac{1}{2} \cos (x+y) + \frac{1}{2} \cos (x-y)$$

Whence:

$$AK \sin (\omega t + \theta) \cos pt = \frac{AK \theta}{2} \sin (\omega t + \theta + pt) + \frac{AK \theta}{2} \sin (\omega t + \theta - pt)$$

Also

$$\cos^2 pt = \frac{1}{2} \cos 2pt + \frac{1}{2}$$

and

$$\frac{AK^2 \theta^2}{2} \cos (\omega t + \theta) \cos^2 pt = \frac{AK^2 \theta^2}{4} \cos (\omega t + \theta) + \frac{AK^2 \theta^2}{4} \cos (\omega t + \theta) \cos 2pt =$$

$$\frac{AK^2 \theta^2}{4} \cos (\omega t + \theta) + \frac{AK^2 \theta^2}{4} [\frac{1}{2} \cos (\omega t + \theta + 2pt) + \frac{1}{2} \cos (\omega t + \theta - 2pt)] =$$

[Continued on next page]

RADIO DESIGN WORKSHEET . . . NO. 26

$$\frac{AK^2 \theta^2}{4} \cos(\omega t + \theta) + \frac{AK^2 \theta^2}{8} \cos(\omega t + \theta + 2pt) + \frac{AK^2 \theta^2}{8} \cos(\omega t + \theta - 2pt)$$

and there results

$$e_2 = A \cos(\omega t + \theta) - \frac{AK \theta}{2} \sin(\omega t + \theta + pt) - \frac{AK \theta}{2} \sin(\omega t + \theta - pt) - \frac{AK^2 \theta^2}{4} \cos(\omega t + \theta) - \frac{AK^2 \theta^2}{8} \cos(\omega t + \theta + 2pt) - \frac{AK^2 \theta^2}{8} \cos(\omega t + \theta - 2pt) + \dots$$

Collecting like terms yields

$$e_2 = \frac{4A - AK^2 \theta^2}{4} \cos(\omega t + \theta) - \frac{AK \theta}{2} \sin(\omega t + \theta + pt) - \frac{AK \theta}{2} \sin(\omega t + \theta - pt) - \frac{AK^2 \theta^2}{8} \cos(\omega t + \theta + 2pt) - \frac{AK^2 \theta^2}{8} \cos(\omega t + \theta - 2pt) + \dots$$

which is the equation for a phase-modulated voltage. This voltage wave contains a carrier

$$\frac{4\theta - AK^2 \theta^2}{4} \cos(\omega t + \theta)$$

a pair of first-order side frequencies,

$$\frac{AK \theta}{2} \sin(\omega t + \theta - pt)$$

and

$$\frac{AK \theta}{2} \sin(\omega t + \theta + pt)$$

a pair of second-order side frequencies,

$$\frac{AK^2 \theta^2}{8} \cos(\omega t + \theta + 2pt)$$

and

$$\frac{AK^2 \theta^2}{8} \cos(\omega t + \theta - 2pt)$$

All are symmetrically disposed about the carrier. This process might have been carried on to yield an infinite series of side frequencies.

From the above equations and as illustrated in *Fig. 1*, the extent of the phase deviation in a pure phase-modulated wave is proportional both to the amplitude and frequency of the modulating signal. Thus, a 500-cycle signal would produce 10 times the phase change of a 50-cycle signal. This is an important characteristic of phase-modulated waves. This is often compensated for in practice by pre-distortion networks which attenuate the high signal frequencies with respect to low signal frequencies before modulation takes place in phase-modulation transmitters.

Fig. 2 shows a physical interpretation of phase modulation. The carrier vector rotates in an anti-clockwise direction at a constant average velocity, but modulation causes it to quiver during rotation in accordance with the modulating signal. Phase and frequency modulation have many important similarities as well as some important differences. This will be discussed in a later worksheet in which the two types of modulation will be compared.

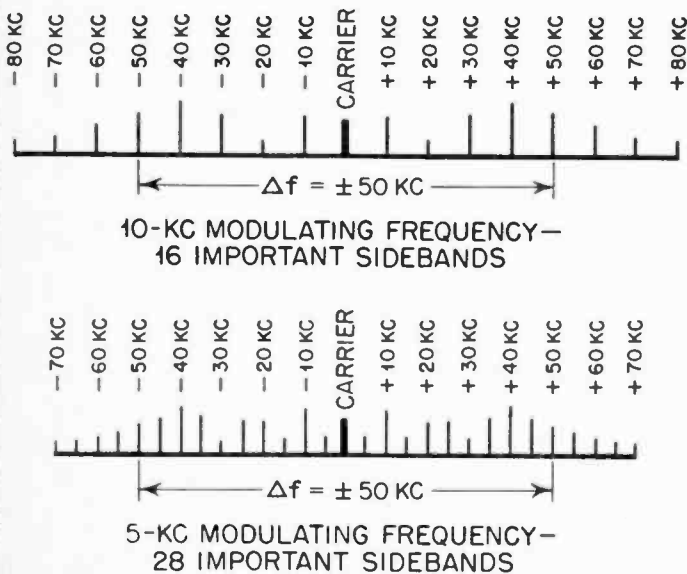

Figure 1

Θ IS THE MAXIMUM EXCURSION OF CARRIER VECTOR OA DUE TO MODULATION

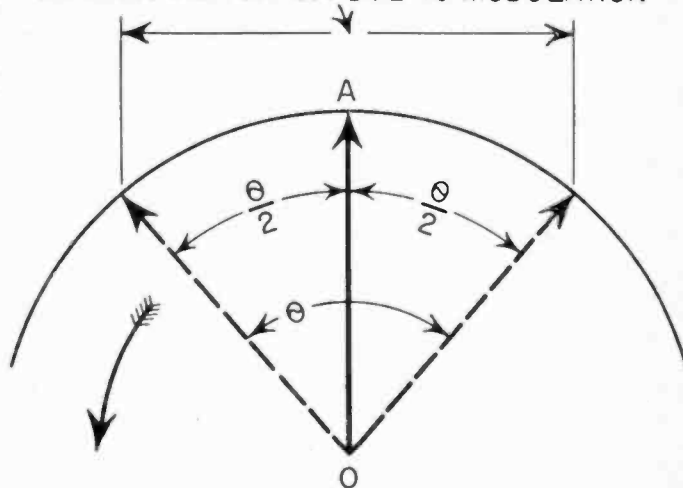

Figure 2

This Month

CIVILIAN RADIO PRODUCTION NOT YET AUTHORIZED BY WPB

Contrary to published reports, the War Production Board has not authorized the production of any new radio receiving sets for civilians and there is no prospect of such authorization this year, the Radio and Radar Division of WPB said today.

Production of radio receiving sets for civilians has been prohibited by WPB since April, 1942. The military electronics equipment program for 1944 is approximately 50 per cent above 1943 production, the Radio and Radar Division pointed out, so the prospect of resumption of civilian radio set production is remote.

Assembly of a limited number of radio receiving sets by manufacturers for military users for morale purposes, such as overseas recreation centers and hospitals, has been authorized, the division said, which may have given rise to reports of resumption of civilian production.

No steps in the direction of authorized production of civilian radio sets would be taken without first consulting the radio industry through the WPB Industry Advisory Committees, the Radio and Radar Division Pointed out.

POST WAR TELEVISION

Once standards have been set by the Federal Communications Commission, every major city in the United States will have a television station just as quickly as transmitter deliveries can be made at the end of the war, it was predicted tonight by *James H. Carmine*, vice president in charge of merchandising for Philco Corporation, in an address on television before the Poor Richard Club at the Franklin Institute.

It may be possible to produce and sell table model television receivers for as little as \$125 after the war, Mr. Carmine said. Larger "projection-type" sets, giving a picture 24 inches by 18 inches may cost up to \$400, he indicated.

PHILIPS APPOINTS LLOYD

North American Philips Company, Inc., announces from its executive offices, 100 East 42nd Street, New York, the appointment of *Warren D. Lloyd* as Commercial Manager of its Medical Division which manufactures X-ray apparatus, X-ray tubes and accessories.

Mr. Lloyd has had over 18 years experience in the medical x-ray field, the last 14 years as New York Office Manager of the General Electric X-ray Corporation.

The Medical Division of North American Philips Company, in its plant at Mt. Vernon, New York, also manufactures X-ray Quartz Crystal Analysis Apparatus, which has helped make possible mass production of quartz crystals for military

communications; X-ray diffraction apparatus, for the quantitative and qualitative analysis and identification of many substances; Searchray (X-ray) for industrial and research applications, and other electronic devices.

The company plans the expansion, as manufacturing restrictions are lifted, of its X-ray, electro-medical, and other allied products program.

MUHLEMAN NOW ERWIN, WASEY EXECUTIVE

M. L. Muhleman, formerly editor and publisher of RADIO MAGAZINE, has joined Erwin, Wasey & Co. in an executive capacity in the Electronics Division. He will devote his efforts largely to the advertising and market research of the North American Philips Company, manufacturers of Electronic Tubes and Measuring Devices, Industrial and Medical

[Continued on page 38]



M. L. MUHLEMAN

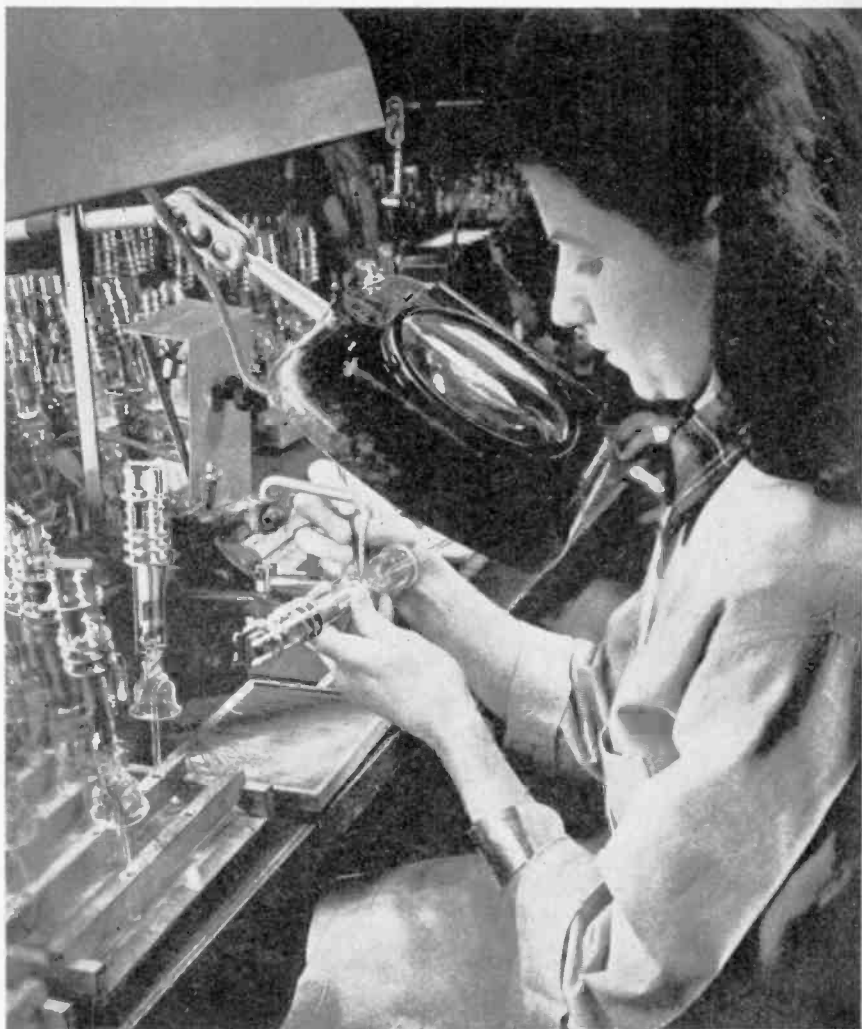

Spot welding connections between cathode-ray tube elements and lead-in wires

This Month

X-Ray Equipment, High Frequency Heating Apparatus, and Tungsten and Molybdenum Products.

Mr. Muhleman has had more than twenty years' experience in the radio-electronic field. He was a radio technician in the U. S. Marine Corps during World War I, and subsequently, spent two years at sea as a commercial operator.

In 1921, he joined the editorial staff of *Radio News* magazine and has since been editorial director of *Radio Engineering*, *Projection Engineering* and *Communication and Broadcast Engineering*, radio editor of *Aviation Engineering*, editor of *All-Wave Radio* and *Radio Service-Dealer*, and a member of the editorial board of *Scientific American*.

[Best of luck, Bud, in your new job.—
J. H. P.]

MECK ADVANCES MONTGOMERY

William Montgomery, who has been serving as production coordinator in the greatly expanded war program of John Meck Industries, radio equipment manu-



WILLIAM MONTGOMERY

facturers, Plymouth, Ind., has been named executive engineer for contact with government agencies, it is announced by John Meck, head of the organization. Associated with Meck for more than three years, Mr. Montgomery was general sales manager before the war.

WADSWORTH WATCH CASE EXPANDS CONTRACT SERVICE

Extensive development of contract service for diverse industries as an important part of postwar expansion is announced by the Wadsworth Watch Case Company. This branch of the business will now be known as the Small Parts Division.

Among industries currently served are aircraft, automotive, bearing, electronics, instruments, machine tool, small arms, refrigeration and many other including forty-five manufacturers for whom one hundred and seventy-five various items are produced.

Widening demand is indicated in an increasing number of fields for quantity production of the very small metal parts with extremely close tolerances which are difficult problems for average plants.

Wadsworth Small Parts Division undertakes this work at any point of manufacture, or from start to finish, together with complete inspection. Service includes design and building of all dies, jigs, fixtures, tools and gages, offers a broad range of machine tools and presses, and is equipped to do finishing in wide variety.

LITTELFUSE NAMES DENISE

Appointment of *Garet W. Denise* to be General Manager of Littelfuse Chicago Plant Operations has just been announced by Littelfuse Incorporated, manufacturer of aircraft fuses and the wide range of instrument fuses and accessories, circuit breakers, thermocouples, fine wire prod-



GARET W. DENISE

ucts, etc., at 4757 Ravenswood Ave., Chicago 40, Ill., and El Monte, Calif.

RCA APPOINTS SADENWATER

The appointment of *Harry Sadenwater*, one of the pioneers in radio's history, as broadcast equipment sales manager for RCA in the Eastern region was announced today by *T. A. Smith*, Standard Radio and Sound Equipment Sales Manager and *M. F. Blakeslee*, Eastern Regional Manager.

Mr. Sadenwater, who will headquarter at the RCA sales offices at 411 Fifth Avenue, New York City, will be responsible for the sale of broadcast transmitters and associated equipment to eastern radio stations. He brings to his new position exceptionally wide experience in installation and operation of many types of radio communications equipment. Prior to his present appointment he was manager of services for RCA Laboratories at Princeton, N. J.

HUTCHINS RETURNS

Henry A. Hutchins, National Union Radio Corporation Sales Executive who took leave of absence to serve with the U. S. Navy, has been returned to civilian life after 20 months of service, according to an announcement this week by *S. W. Muldowny*, President of the Corporation.

Mr. Hutchins has resumed his National Union activities with headquarters at the concern's executive offices in Newark, New Jersey.

UTAH APPOINTS STEVENSON

William J. Stevenson, General Counsel for the Utah Radio Products Company, was today named as Secretary of the Company, according to an announcement from *Fred R. Tuerk*, President of the Company.

Mr. Stevenson has been identified with the Company for the past seven years. *W. Dumke*, who has been Secretary as well as Vice President in Charge of Production, requested that, owing to the



W. J. STEVENSON

pressure of war production, he be relieved of secretarial duties. In addition to being an officer of the Company, Mr. Dumke is also a Director.

SCIENTIST REFUTES MAGNETIC FLOW THEORY

The theory of magnetic current—which if true would revolutionize century-old concepts of electricity—was refuted by a Pittsburgh scientist who claimed that rigidly-controlled experiments had proved that magnetism does not flow in the same manner as electric current.

Dr. Jacob E. Goldman, of the Westinghouse Research Laboratories, speaking before the American Physical Society, recently said that the experiments, conducted along the exact lines of those of Professor Felix Ehrenhaft, Viennese physicist and leading proponent of magnetic current, had produced conclusive, negative results.

[Continued on page 58]

New Products

MINIATURE INDUCTOR COILS

Miniature Air Inductor Coils just introduced by Barker and Williamson, 235 Fairfield Ave., Upper Darby, Pa., offer a wide range of engineering possibilities in high frequency radio and other electronic applications.

They are regularly supplied in diameters from $\frac{1}{2}$ " to $1\frac{1}{4}$ ". "Air Wound" construction assures maximum rigidity and accuracy, with lightest possible weight. Q characteristic is amazingly high due to the almost total absence of insulating material in the electrical field.

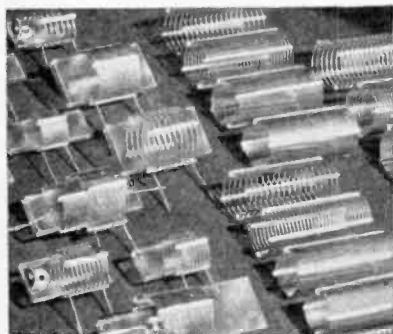

Any type of mounting can be supplied, and the little coils can be equipped with fixed or variable, internal or external coupling links, and many other features to match practically any specification. There are 5 standard diameters and each diameter is available in any winding pitch from 44 to 4 turns per inch, or less if required. Wire sizes range from No. 14 to No. 28 and almost any desired type of wire can be supplied. Design adaptations are limitless. Samples will be sent to quantity users. New, illustrated catalog on request to manufacturer.

FREE STROBOSCOPES

The Universal Microphone Co., Inglewood, Cal., has re-issued the Stroboscope for bulk distribution to the trade. The firm published the device some years ago on a "cost price" base, but the present edition will be distributed gratis.

Printed on heavy stock with complete instructions, the setup will include individual folders in which to preserve and file the Stroboscope.

Distribution will be from the factory in Inglewood with sufficient space on each for trade imprint of individual firms. Universal's factory representatives may be contacted by jobbers, while dealers in turn can get their supply from wholesalers.

Although, in general, this procedure will result in speedy delivery of the giveaways, in instances where this routine is not practicable, the trade can contact the factory direct.

Designed to work at 33 1/3 and 78 rpm. under a light of 25, 50 or 60 cycles, the stroboscope is the generally accepted

method of determining the exact turntable speed for high quality reproduction of phonograph records and transcriptions, thus enabling reproduction with true pitch and tempo.

Radio and recording studios, as well as individual owners of phonographs, radio-phono and recorder combinations are the natural prospects for dealers to pass on the Stroboscope in building up a prospect or mailing list.

NEW LAFAYETTE CATALOG

The publication of a catalog supplement No. 95 containing a listing of a wide assortment of radio and electronic parts, has been announced by the Lafayette Radio Corporation.

Several hundred diversified radio components including tubes, resistors, volume controls, wire, batteries, coils, condensers, speakers, switches, relays, radio cabinets, radio panels, blank metal chassis, servicing manuals, transformers, technical books, and many more miscellaneous items are listed. These are available in stock for immediate delivery, however, the quantities of the items are limited and subject to prior sale.

Copies may be obtained by writing immediately to the Lafayette Radio Corporation, 901 West Jackson Blvd., Chicago, Ill., or 265 Peachtree Street, Atlanta 3, Georgia, asking for Catalog No. 95.

NEW UNIVERSAL BRIDGE

A new Universal Bridge, Model 1010, has been announced by White Research, 899 Boylston St., Boston 15, Mass., which incorporates many exceptional features. Resistance range is from 10^{-4} to 10^{10} ohms; capacitance range, from 10^{-6} to 100 μ F; inductance range, with no d-c flowing, 10^{-9} to 100 henrys and, with superimposed d.c. 0.1 to 100 henrys.

Inductance of iron-cored chokes and transformers can be measured with up to 500 ma of d.c. flowing. Facilities for measurement of frequency, Q, and power factor are included.

The bridge contains a 1-megohm decade in steps of 1 ohm, which is brought out to terminals so that it may be used externally.

FUNGUS-RESISTANT LACQUER

Communications equipment that soon became useless in tropical climates is now being protected from high humidity and fungus growth by a new lacquer, developed by Maas & Waldstein Company, manufacturer of industrial finishes.

When our troops first entered the tropics, moisture saturated ground signal equipment and provided an ideal breeding ground for fungi. These growths, absorbing and holding water like blotting paper, covered parts of equipment and caused short circuits.

At the request of the Signal Corps for assistance on this problem, Maas & Waldstein developed a lacquer that is moisture-resistant, has high dielectric strength, and retards the growth of fungi. It is now being used on Signal and other communication equipment at our tropical bases.

The new lacquer, marketed as Dulac Fungus-Resistant lacquer No. 86-, may also be used to treat communications equipment before it is assembled and shipped to the tropics. Complying with U. S. Signal Corps Specification No. 71-2202-A, it is a clear, quick-drying lacquer that may be applied by spraying, brushing or dipping.

NEW G-E ELECTRONIC RELAY

A new electronic relay for amplifying the very limited current transmitted by delicate control contacts or high resistance circuits, thus materially increasing the application range of many control devices, has been announced by the Industrial Control Division of the General Electric Company. Operated by any material having a resistance of from 0 to 500,000 ohms, or even greater if necessary, the new relay is especially suitable for controlling liquid levels in tanks and boilers, sorting metallic parts by size, detecting broken threads in textile machines, and as a limit switch requiring extremely light pressure to operate.

Small and light in weight, thus facilitating easy installation, the new relay consists of a standard type electronic tube, a supply transformer, and an electromagnetic relay—all mounted in a totally enclosed, weather-resistant enclosure suitable for wall or machine mounting.

In operation, the electromagnetic relay in the device is kept energized as long as

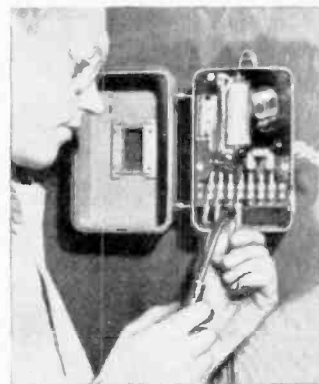

the controls connected to the input grid circuit of the electronic tube remain open. The instant these contacts close, the relay is de-energized. A built-in time delay feature prevents chattering when the contacts in the input circuit are momentarily closed. A contact arrangement on the electromagnetic relay permits the device

[Continued on next page]

New Products

to be used either to make or break a load circuit when the actuating contacts connected to the input circuit on the electronic relay are closed.

PORTABLE SUPERTESTER MULTITESTER BY RADIO CITY PRODUCTS

The RCP Model 422 Supertester is equivalent to 27 individual instruments in one compact unit—with very low and very high ranges. Excellent for general circuit testing—speeds up trouble shooting—and combines many important measure-



ments in one small case. Features are: Current measurements in both A.C. and D.C. up to 25 amperes; Voltage measurements in both A.C. and D.C. up to 5,000 volts; High Voltage not applied to selector switch nor to general test circuits. 3-inch square meter with movement of 200 microamperes or 5,000 ohms per volt sensitivity on D.C. voltage measurements. Resistance measurements up to 10 megohms. Batteries are replaceable without a soldering iron. Supplied complete with batteries in natural wood case—6½" x 7" x 2¾"—with carrying strap handle.

Complete details of this tester and other RCP radio, electrical and electronic testing instruments are contained in the new RCP Catalog No. 128 of standard commercial models. Copies are available on request to Radio City Products Company, 127 West 26th Street, New York 1, N. Y.

NEW METERS

A complete line of "Dale" electrical voltmeters, ammeters, micrometers, and milliammeters are available in standard 2" and 3" AWS case construction. The d-c instruments embody all requirements necessary for exacting and rugged use.

A solid bakelite bridge construction of sturdy conventional design forms the body of the movement. Incorporated also are soft iron pole pieces which guarantee a uniform scale distribution. A special type of balance system has been employed to

assure a good balance for all positions of mounting.

The instruments are manufactured in a modern air conditioned factory designed especially for producing meters under ideal conditions.

Complete facilities and engineering talent is available to develop and produce special instruments.

These meters are manufactured by Dale Instruments Electronic Development Co., 2055 Harney Street, Omaha 2, Nebraska.

NEW RESISTOR CATALOG

Just off the press is the new 1944 Catalog "Resistors by Haines" showing and detailing the Haines basic line of Vitreous Enamelled Wire-Wound Army-Navy type resistors. Copies are available to interested manufacturer's representatives and purchasing Agents. Write Haines Manufacturing Co., 248-274 McKibbin St., Brooklyn 6, N. Y.

EMERSON BOOK

"Small Radio, Yesterday and In The World of Tomorrow," titles an impressive book on that subject and on the vast strides of electronic development during the past two years, which is now being issued by the Emerson Radio and Phonograph Corporation.

BETTER SUPPRESSORS

Postwar America can look forward to vastly superior short-wave radio reception if auto makers adopt the war-developed technique which eliminates radio interference from the engines of mechanized weapons, it was declared by Delmar G. Roos, vice-president in charge of engineering for Willys-Overland Motors.

The resultant improvement in the field of high frequency broadcasting would be of sufficient magnitude, he pointed out, to warrant enactment of legislation which would assure peacetime application of this radio development to all new automobiles.

Such a legal requirement, Mr. Roos added, would bring about the "suppression" of all cars and trucks on the highway within a period of five to seven years and thus, by releasing a vast number of short-wave bands previously denied the public, would clear the way for infinitely better auto and home radio reception.

This technique, Mr. Roos disclosed, has been in effective operation for more than a year on tanks, "Jeeps" and half-tracks. Previously, it was difficult to transmit and pick up dispatches on certain short-wave bands, especially when these vehicles were traveling in convoy or close battle formation, owing to the radio interference emanating from their electrical equipment.

SURGE RESISTORS

Developed for the X-Ray and other high-voltage applications, Shallcross Type 290 Wire-Wound Surge Resistors match modern requirements for high-resistance units capable of handling high voltage, while dissipating normally 200 watts. A

typical application is their use in the constant potential d-c output of a high voltage Kenetron rectifying system to stabilize the performance of the apparatus to which this high potential is being applied, the resistors operating either as bleeders or as voltmeter multipliers.

These surge resistors are wound on high-grade non-hygroscopic ceramic forms with insulated nichrome wire, single layer space-wound. The wire is protected with a special finish which reinsulates, resists heat and can assure operation at 450° F. Any resistance from 1,000 to 3,000,000 ohms are available. Descriptive literature is available from the Shallcross Manufacturing Company, Jackson and Pusey Avenues, Collingdale, Penna.

CETRON CE-305

The CE-305 gas-filled thyratron tube has been introduced by Continental Electric Company, Geneva, Illinois, to fill a need for a medium current tube that will stand higher-than-usual voltage. Prior to the introduction of this type, no gas-filled tube in this current and voltage range had been available.

The CE-305 finds its principal applications in the industrial field, where it is

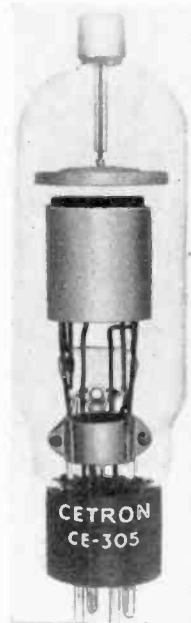

particularly suited to the following applications:

1. Resistance welder control
2. Motor control
3. Controlled rectifiers

Being gas-filled, it is especially suitable where large temperature changes are involved. The CE-305 is quick-heating.

It uses a standard 4-pin base and has a maximum peak inverse rating of 1,700 volts. It has a d.c. output current rating of 2 amperes. Additional technical details are covered by data sheet No. 116, which will be sent on request to manufacturer.

HOGARTH DOESN'T MIND—HE'S USED TO HAVING
A CROWD AROUND HIS **ECHOPHONE EC-1**

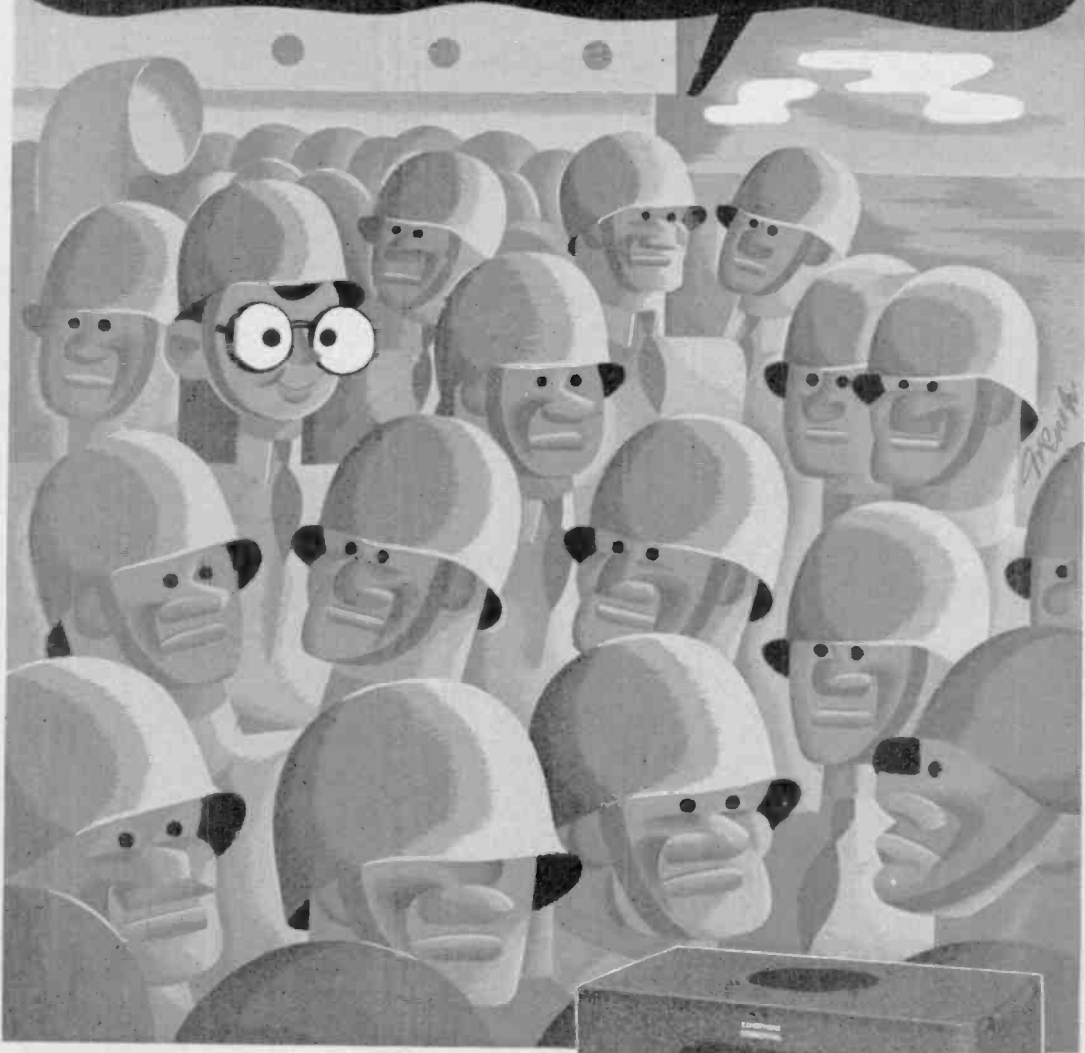

ECHOPHONE MODEL EC-1

(Illustrated) a compact communications receiver with every necessary feature for good reception. Covers from 550 kc. to 30 mc. on 3 bands. Electrical bandspread on all bands. Six tubes. Self-contained speaker. 115-125 volts AC or DC.



ECHOPHONE RADIO CO., 540 NORTH MICHIGAN AVE., CHICAGO 11, ILLINOIS

RADIO BIBLIOGRAPHY

F. X. RETTENMEYER

RCA Victor Division
Radio Corporation of America

No. 16—TRANSMITTERS

Mobile Television Equipment—R. L. Campbell, R. E. Kessler, R. E. Rutherford and K. U. Landsberg—*Proceedings IRE*, Vol. 30, No. 1, Jan. 1942, page 1.

Orthicon Portable Television Equipment—M. A. Trainer—*Proceedings IRE*, Vol. 30, No. 1, Jan. 1942, page 15.

On Radiation from Antennas—S. A. Schelkunoff and C. B. Feldman—*Proceedings IRE*, Vol. 30, No. 11, Nov. 1942, page 511.

A Graphical Method of Finding the Optimum Operating Conditions of Triodes as Class C Telegraph Transmitters—J. C. Frommer—*Proceedings IRE*, Vol. 30, No. 11, Nov. 1942, page 519.

E. C. O. Coupling Circuit—*QST*, Vol. XXV, Jan. 1941, page 42.

Variarm 150—Rice—*QST*, Vol. XXV, Jan. 1941, page 8.

Pocket-Size Complete Transmitters—Hanes and Lawrence—*QST*, Vol. XXV, Jan. 1941, page 12.

Low Power Transmitter for Demonstrating Frequency Modulation Receivers—M. Hobbs—*Electronics*, Vol. XIV, Jan. 1941, page 20.

Inexpensive Two-Stage Three-Band Transmitter—Chambers—*QST*, Vol. XXV, Feb. 1941, page 16.

Compact 56-MC Converter—Goodman—*QST*, Vol. XXV, Feb. 1941, page 8.

Simple 5 and 10-Meter Transmitter—Thompson—*QST*, Vol. XXV, Feb. 1941, page 20.

Flea-Power AC/DC Phone—Chambers—*QST*, Vol. XXV, March 1941, page 22.

Automatic Overload Protection of Tubes—*QST*, Vol. XXV, March 1941, page 57.

Gang-Tuned V. F. O.—Goodman—*QST*, Vol. XXV, March 1941, page 14.

Push-Pull 809's in a Low-Frequency Transmitter—Mix—*QST*, Vol. XXV, March 1941, page 32.

Simple Tone Modulation for U. H. F. Transmitters—*QST*, Vol. XXV, March 1941, page 56.

Push to Talk—*QST*, Vol. XXV, April 1941, page 57.

Compact Portable-Emergency Transmitter—Chambers—*QST*, Vol. XXV, April 1941, page 24.

Portable-Emergency Transmitter for Vibrator Power Supply—Roberts—*QST*, Vol. XXV, April 1941, page 32.

The QST-25—Sutter—*QST*, Vol. XXV, April 1941, page 40.

"Bugless" 5-Meter Transmitter—Barrett and Melton—*QST*, Vol. XXV, April 1941, page 14.

Inductive Tuning at Ultra-High Frequencies—*Electronics*, Vol. XIV, April 1941, page 32.

Water-Cooled Resistors for Ultra-High Frequencies—Brown & Conklin—*Electronics*, Vol. XIV, April 1941, page 24.

Emergency Transmitter Design Considerations—Reda & Stiles—*QST*, Vol. XXV, May 1941, page 36.

Low-Powered 112-MC Transmitter-Receiver—Goodman—*QST*, Vol. XXV, May 1941, page 20.

Fool-Proof Rig for 80 and 40 Meters—Mix—*QST*, Vol. XXV, June 1941, page 20.

Transmitter Frequency-Control Unit with Three-Band Output—Stuart—*QST*, Vol. XXV, June 1941, page 45.

Balanced Inductive Coupling for U. H. F.—*QST*, Vol. XXV, June 1941, page 56.

An Inexpensive 56-MC Exciter or Transmitter—Chambers—*QST*, Vol. XXV, June 1941, page 13.

Simplifier I. C. W. Operation—*QST*, Vol. XXV, June 1941, page 57.

Versatile Portable-Emergency Transmitter—Hadlock—*QST*, Vol. XXV, July 1941, page 9.

Apartment-Size 100-Watt Transmitter—Woehr—*QST*, Vol. XXV, July 1942, page 12.

Applying the Dynamic Shift Principle—F. A. Everest & F. H. Dickson—*Communications*, Vol. 21, No. 7, July 1941, page 3.

Further Developments in the Fool-Proof Rig—Mix—*QST*, Vol. XXV, Aug. 1941, page 30.

An Inexpensive 112-MC M. O. P. A.—Johnson—*QST*, Vol. XXV, Aug. 1941, page 12.

Modulator and Power Supply for the Inexpensive 56-MC Transmitter—Chambers—*QST*, Vol. XXV, Aug. 1941, page 18.

227-MC at W1AIY—*QST*, Vol. XXV, Aug. 1941, page 38.

Frequency-Halving Oscillators—Goodman and Bubb—*QST*, Vol. XXV, Sept. 1941, page 46.

Adapting the 6L6 Oscillator for Fundamental and Harmonic Operation—*QST*, Vol. XXV, Sept. 1941, page 58.

New Miniature U. H. F. Receiving Tubes in a 56 & 112 MC Converter—Grammer—*QST*, Vol. XXV, Sept. 1941, page 18.

An 80-Watt All-Band Transmitter or Exciter—Goodman—*QST*, Vol. XXV, Oct. 1941, page 15.

56-MC Transmitter for Mobile Work—Goodman and Bubb—*QST*, Vol. XXV, Oct. 1941, page 50.

Low-C Electron Coupled Oscillator—Seiler—*QST*, Vol. XXV, Nov. 1941, page 26.

Variable Crystal Frequency With an 815 Locked Oscillator—*QST*, Vol. XXV, Nov. 1941, page 53.

A Soldier's Portable—Roof—*QST*, Vol. XXV, Nov. 1941, page 22.

Mobile Transmitter for 2½ Meters—Chambers—*QST*, Vol. XXV, Nov. 1941, page 36.

Power Amplifier Plate Tank Circuits—*Electronics*, Vol. XIV, Nov. 1941, page 32.

Amplifier Neutralization with Safety—*QST*, Vol. XXV, Dec. 1941, page 47.

112-MC Emergency Transmitter—Grammer—*QST*, Vol. XXV, Dec. 1941, page 14.

A Net Unit Type Multi-Frequency 5 Kilowatt Transmitter Equipment—Martin—*Electrical Communication*, Vol. 19, No. 4, 1941, page 93.

Another Compact Multiple Crystal Mounting—*QST*, Vol. XXIV, Jan. 1940, page 64.

Another Harmonic Oscillator Circuit—*QST*, Vol. XXIV, Jan. 1940, page 64.

Getting Results with the Pierce Oscillator—*QST*, Vol. XXIV, Jan. 1940, page 65.

Compactness with Economy—Monderer—*QST*, Vol. XXIV, Jan. 1940, page 34.

Lop-Sided Speech and Modulation—Grammer—*QST*, Vol. XXIV, Feb. 1940, page 14.

Another Approach to High Power—McCullough—*QST*, Vol. XXIV, Feb. 1940, page 54.

Instant Band-Change with Push-Button
[Continued on page 44]



It's CQ from the Battlefield Today!



You remember him, the kid next door who tinkered with short wave radio. Well, he's in uniform now, calling his CQ from foxholes in Italy and steaming Pacific jungles. Maybe, he's a radio operator on a bomber . . . perhaps, he's an instructor. Whatever it is, you can be sure that his knowledge and experience are serving to help build a wartime communications system. Yes, from the hams came ready trained instructors, operators and engineers at a time when skilled technicians were vitally needed.

The radio amateur will be back one of these days, back to his much-loved tinkering. He'll want new equipment to add to his short wave rig. . . . He'll be looking for a JENSEN speaker because he wants highest fidelity in music, code and voice reproduction. There is no finer acoustic equipment than JENSEN reproducers.

*Manufacturers and Designers
of Fine Acoustic Equipment*

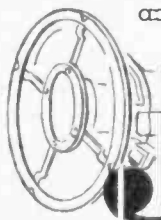

Jensen

RADIO MANUFACTURING COMPANY
6601 S. LARAMIE AVE., CHICAGO 38, U. S. A.

RADIO BIBLIOGRAPHY

- Control—Linn—*QST*, Vol. XXIV, Feb. 1940, page 11.
- High Frequency RF Amplifiers—E. J. O'Brien and H. Tees—*Communications*, Vol. 20, No. 2, Feb. 1940, page 7.
- Automatic Water-Stage Transmitters—M. C. Kennedy—*Communications*, Vol. 20, No. 2, Feb. 1940, page 10.
- Neutralizing Economy—Hansen — *QST*, Vol. XXIV, March 1940, page 28.
- Neutralization—*QST*, Vol. XXIV, March 1940, page 52.
- A Plug-in Oscillator Unit—*QST*, Vol. XXIV, March 1940, page 60.
- A Practical 112 MC Converter—*QST*, Vol. XXIV, March 1940, page 16.
- The Design of Speech Amplifiers—Millington and Path—*QST*, Vol. XXIV, April 1940, page 50.
- A Simplified Exciter Circuit—MacGeorge—*QST*, Vol. XXIV, April 1940, page 2.
- A Hundred-Dollar Half Kilowatt—Osborne—*QST*, Vol. XXIV, April 1940, page 34.
- 160 to 2½ in One Transmitter—Tilton—*QST*, Vol. XXIV, April 1940, page 23.
- A Battery Transceiver for 112-MC—Chambers—*QST*, Vol. XXIV, April 1940, page 28.
- A Complete 5-MC I-F System—Goodman—*QST*, Vol. XXIV, April 1940, page 16.
- A 56-MC Crystal Controlled Transceiver—Jacobs—*QST*, Vol. XXIV, April 1940, page 46.
- Notes on FM Transmitters—F. A. Gunther—*Communications*, Vol. 20, No. 4, April 1940, page 11.
- Cathode Modulation—*QST*, Vol. XXIV, May 1940, page 38.
- Flasher Type Over-Modulation Indicators—*QST*, Vol. XXIV, May 1940, page 37.
- Narrow-Band Constant-Level Speech Amplification—Turney & Shimney—*QST*, Vol. XXIV, May 1940, page 54.
- Voltmeter as Sensitive Neutralization Indicator—*QST*, Vol. XXIV, May 1940, page 58.
- Extended Variable Frequency Crystal Control—Goodman—*QST*, Vol. XXIV, May 1940, page 91; *QST*, Vol. XXIV, June 1940, page 7.
- A Compact 112-MC Station—Lawrence—*QST*, Vol. XXIV, May 1940, page 15.
- A 56-MC Mobile Station—Lynch—*QST*, Vol. XXIV, May 1940, page 40.
- Simple Modulation Monitor and Percentage Indicator—*QST*, Vol. XXIV, June 1940, page 69.
- Overload Relay with Electrical Reset—*QST*, Vol. XXIV, June 1940, page 70.
- Single Dial Frequency Control—Rice—*QST*, Vol. XXIV, June 1940, page 30.
- Notes on E. C. O. Drift—*QST*, Vol. XXIV, June 1940, page 68.
- The QSL Push-Pull—Sutter—*QST*, Vol. XXIV, June 1940, page 26.
- A Traffic Transmitter—Baker—*QST*, Vol. XXIV, June 1940, page 52.
- Neutralizing R. F. Stages with a Modulation Monitor—*QST*, Vol. XXIV, July 1940, page 51.
- A Heterodyne Exciter—Bliss and Bailey—*QST*, Vol. XXIV, July 1940, page 38.
- A Stabilized Variable Frequency Oscillator—Brown—*QST*, Vol. XXIV, July 1940, page 13.
- A Different Portable-Emergency Transmitter—Austin—*QST*, Vol. XXIV, July 1940, page 36.
- A Portable Transmitter-Receiver—Hildebrand—*QST*, Vol. XXIV, July 1940, page 42.
- Portable Kinks — Dreyer — *QST*, Vol. XXIV, July 1940, page 18.
- An Acorn Tube 112-MC Converter—Rehm—*QST*, Vol. XXIV, July 1940, page 41.
- Flexible Beam Power Transmitter—E. F. Kiernan—*Electronics*, Vol. XIII, Aug. 1940, page 40.
- Three-Band Coil—*QST*, Vol. XXIV, Aug. 1940, page 44.
- Designing a Wide-Range U.H.F. Receiver—Achor—*QST*, Vol. XXIV, Aug. 1940, page 34.
- Automatic Tuning for the Amateur Transmitter—Atkings and Read—*QST*, Vol. XXIV, Sept. 1940, page 20.
- On the Right- and Left-Handedness of Quartz and Its Relation to Elastic and Other Properties—K. S. Van Dyke—*Proceedings IRE*, Vol. 28, No. 8, Aug. 1940, page 399.
- A Midget 1.75 and 3.5 MC Phone Transmitter—Gordon—*QST*, Vol. XXIV, Oct. 1940, page 42.
- Fool-Proof Screen Feed—Roberts—*QST*, Vol. XXIV, Oct. 1940, page 38.
- Magnetic Bandswitching—Bellem—*QST*, Vol. XXIV, Oct. 1940, page 54.
- An E. C. O. Exciter with 20 Watts Output—Mix—*QST*, Vol. XXIV, Oct. 1940, page 22.
- A Sailor's Five Tube Station—Jennings—*QST*, Vol. XXIV, Oct. 1940, page 69.
- Magnetic Bandswitching—Bellem — *QST*, Vol. XXIV, Oct. 1940, page 54.
- Centimeter Waves Coming Up! — *QST*, Vol. XXIV, Oct. 1940, page 32.
- A New Broadcast Transmitter Chart Design for F. M.—J. F. Morrison—*Proceedings IRE*, Vol. 28, No. 10, Oct. 1940, page 444.
- Link Coupling Between Transmitter Stages—Roberts—*QST*, Vol. XXIV, Nov. 1940, page 41.
- An Electron-Coupled Oscillator, 1940 Model—Southworth—*QST*, Vol. XXIV, Nov. 1940, page 26.
- Composite Oscillator—*QST*, Vol. XXIV, Nov. 1940, page 47.
- A Simple Two-Tube Exciter—Mix—*QST*, Vol. XXIV, Nov. 1940, page 91.
- A Stabilized 2½ Meier Oscillator—Goodman—*QST*, Vol. XXIV, Nov. 1940, page 33.
- High-Frequency Broadcast Chart—*Electronics*, Vol. XXIV, Dec. 1940, page 41.
- The 6L6 as Crystal Oscillator—Mix—*QST*, Vol. XXIV, Dec. 1940, page 54.
- A Double-Beam Power U. H. F. Transmitter—Goodman—*QST*, Vol. XXIV, Dec. 1940, page 40.
- A Microwave Superhet—Lewis—*QST*, Vol. XXIV, March 1940, page 16.
- An Experimental Single Side Band Transmitter—C. B. Aiken & S. H. Lok—*Communications*, Vol. 19, No. 2, Feb. 1939, page 10.
- Oscillations in Certain Nonlinear Driven Systems—D. L. Herr—*Proceedings IRE*, Vol. 27, No. 6, June 1939, page 386.
- A 50-Kilowatt Broadcast Station Utilizing the Doherty Amplifier and Designed for Expansion to 500 Kilowatts—W. H. Doherty & W. O. Tower—*Proceedings IRE*, Vol. 27, No. 9, Sept. 1939, page 531.
- Net Ultra High Frequency Transmitters—*Communications*, Vol. 19, No. 12, Dec. 1939, page 10.
- A 200-Kilowatt Radiotelegraph Transmitter—G. W. Hansell & G. L. Usselman—*RCA Review*, Vol. II, April 1938, page 442.
- Application of Styrene to H. T. Cable Systems—T. R. Scott & J. K. Webb—*Electrical Communications*, Vol. 17, July 1938, page 88.
- Buenos Aires Broadcasting Station LS-1—R. E. Coram, W. H. Capen, and A. S. Kishpaugh — *Electrical Communications*, Vol. 17, July 1938, page 66.
- High-Efficiency Modulation System—R. B. Dome—*Proceedings IRE*, Vol. 26, No. 8, Aug. 1938, page 963.
- A Phase-Opposition System of Amplitude Modulation—L. F. Gaudernack—*Proceedings IRE*, Vol. 26, No. 8, Aug. 1938, page 983.
- Partial Suppression of One Side Band in Television Reception—W. J. Poch and D. W. Epstein—*Proceedings IRE*, Vol. 25, No. 1, Jan. 1937, page 15.
- Ultra-High-Frequency Wave Propagation Over Plane Earth and Fresh Water—R. C. Colwell and A. W. Friend—*Proceedings IRE*, Vol. 25, No. 1, Jan. 1937, page 32.
- The Surface Wave in Radio Propagation Over Plane Earth—C. R. Burrows—*Proceedings IRE*, Vol. 25, No. 2, Feb. 1937, page 219.
- 300-Watt Marine Radio Telegraph Transmitter—I. F. Byrnes—*RCA Review*, Vol. I, April 1937, page 119.
- A Low-Power Transmitter—J. P. Elroy—*Communication & Broadcast Eng.*, Vol. 4, No. 6, June 1937, page 14.
- The Shunt-Excited Antenna—J. F. Morrison and P. H. Smith—*Proceedings IRE*, Vol. 25, No. 6, June 1937, page 673.
- A New Power Amplifier of High Frequency—W. H. Doherty—*Communication & Broadcast Eng.*, Vol. 3, No. 5, May 1936, page 7.
- Technical Digests—A New High-Efficiency Power Amplifier for Modulated Waves—W. H. Doherty—*Bell System Technical Journal*, Vol. XV, July 1936, page 469.
- Modes of Oscillation in Barkhausen-Kurz Tubes—W. D. Hershberger—*Proceedings IRE*, Vol. 24, No. 7, July 1936, page 964.
- Recent Developments of the Class B Audio- and Radio-Frequency Amplifiers—L. E. Barton—*Proceedings IRE*, Vol. 24, No. 7, July 1936, page 985.
- Ultra-High-Frequency Transmission Between the RCA Building and the Empire State Building in New York City—P. S. Carter & G. S. Wickizer—*Proceedings IRE*, Vol. 24, No. 8, Aug. 1936, page 1082.
- Magnetron Oscillators for the Generation of Frequencies Between 300 and 600 Megacycles—G. R. Kilgore—*Proceedings IRE*, Vol. 24, No. 8, Aug. 1936, page 1140.
- A New High Efficiency Power Amplifier for Modulated Waves—W. H. Doherty—*Proceedings IRE*, Vol. 24, No. 9, Sept. 1936, page 1163.
- Low Power Broadcast Stations—R. C. Powell—*Communication & Broadcast Eng.*, Vol. 2, No. 1, Jan. 1935, page 18.

[Continued on page 46]

The **ONLY**
Resistors
wound with
***CERAMIC
INSULATED
WIRE!**



**IT'S FLEXIBLE*

**IT'S
MOIS-
TURE-
PROOF*



**IT'S HEAT-PROOF
TO 1000°C*

**IT PERMITS USE OF
LARGER WIRE SIZES
IN LESS SPACE*

A MAJOR RESISTOR IMPROVEMENT

The outstanding superiority of Sprague Koolohm Resistors in practically every important characteristic could—and did—result only from an entirely different engineering approach to basic problems—from the wire up. Research proved that the resistor was no better than the insulation on the wire. Koolohm ceramic insulation applied to resistance wire permitted such valuable engineering features that, in less than four years, these resistors have set higher standards of performance on hundreds of the most exacting applications. Standard units include 5- to 150-watt power types, bobbin types and meter multipliers. Write for Catalog—today!

SPRAGUE ELECTRIC CO.
(Formerly Sprague Specialties Co.)



RESISTOR DIVISION
NORTH ADAMS, MASS.

**SOLVING
PROBLEMS**
of
**UNWIELDY SIZE
REDUCED WATTAGES
CHANGED VALUES
HIGH AMBIENTS
MOUNTINGS
SHORTS**
... and many more!

SPRAGUE KOOLOHM RESISTORS

Increasing Power of Broadcast Transmitters—R. C. Powell—*Communication & Broadcast Eng.*, Vol. 2, No. 2, Feb. 1935, page 15.

High Fidelity Broadcasting—J. J. Long—*Communication & Broadcast Eng.*, Vol. 2, No. 2, Feb. 1935, page 19.

Maintaining and Measuring the Frequency of Radio Transmitters—E. J. Andrew—*Communication & Broadcast Eng.*, Vol. 2, No. 3, March 1935, page 13.

Class B and C Amplifier Computations—V. A. Babits—*Communication & Broadcast Eng.*, Vol. 2, No. 7, July 1935, page 7.

The High-Quality Problem—J. A. Hutchinson—*Communication & Broadcast Eng.*, Vol. 2, No. 7, July 1935, page 19.

Improving the Class B Amplifier—C. E. Replege—*Communication & Broadcast Eng.*, Vol. 2, No. 8, Aug. 1935, page 12.

An Unattended Ultra-Short-Wave Radio-telephone System—N. F. Schlaack and F. A. Polkinghorn—*Proceedings IRE*, Vol. 23, No. 11, Nov. 1935, page 1275.

High Fidelity Transmitter—J. E. Young—*Radio Engineering*, Vol. XIV, No. 3, Mar. 1934, page 18.

Design of Power Tube Circuits—R. Lee—*Radio Engineering*, No. 7, July 1934, page 10.

High Fidelity Broadcast Class B Modulation—I. A. Mitchell—*Communication & Broadcast Eng.*, Vol. 1, No. 1, Oct. 1934, page 23.

The Transmitter—R. D. Kell, A. V. Bedford, and M. A. Trainer—*Proceedings IRE*, Vol. 22, No. 11, Nov. 1934, page 1246.

Radio Vienna—P. M. Homell—*Communication & Broadcast Eng.*, Vol. 1, No. 3, Dec. 1934, page 7.

Class B Radio Frequency Amplifiers—C. L. Farrer—*Communication & Broadcast Eng.*, Vol. 1, No. 3, Dec. 1934, page 12.

Application of A-Prime Amplification to a 100-Watt Broadcast Transmitter—I. A. Mitchell—*Communication & Broadcast Eng.*, Vol. 1, No. 3, Dec. 1934, page 18.

The Optics of Radio Transmission—E. Merritt—*Proceedings IRE*, Vol. 20, No. 1, Jan. 1932, page 29.

The Prague High-Power Broadcasting Equipment—D. B. Mirk—*Electrical Communications*, Vol. 10, Jan. 1932, page 106.

Quartz Plate Mountings and Temperature Control for Piezo Oscillators—V. E. Heaton and E. G. Lapham—*Proceedings IRE*, Vol. 20, No. 2, Feb. 1932, page 261.

Characteristics of the UV-858 Power Tube for High-Frequency Operation—H. A. Acheson and H. F. Dart—*Proceedings IRE*, Vol. 20, No. 3, March 1932, page 449.

Empirical Standards for Broadcast Allocation—A. D. Ring—*Proceedings IRE*, Vol. 20, No. 4, April 1932, page 611.

The Vibration of Quartz Plates—R. C. Colwell—*Proceedings IRE*, Vol. 20, No. 5, May 1932, page 808.

Direct-Ray Broadcast Transmission—T. L. Eckersley—*Proceedings IRE*, Vol. 20, No. 10, Oct. 1932, page 1555.

Crystal Control Applied to the Dynatron Oscillator—K. A. MacKinnon—*Proceedings IRE*, Vol. 20, No. 11, Nov. 1932, page 1689.

Measurement of Power and Efficiency of Radio Transmitting Apparatus—G. Pession and T. Gorio—*Proceedings IRE*, Vol. 19, No. 3, March 1931, page 377.

Output Networks for Radio-Frequency Power Amplifiers—W. L. Everitt—*Proceedings IRE*, Vol. 19, No. 5, May 1931, page 725.

The Suppression of Radio-Frequency Harmonics in Transmitters—J. W. Labus and H. Roder—*Proceedings IRE*, Vol. 19, No. 6, June 1931, page 949.

A New Rectifier—V. Bush and C. G. Smith—*Proceedings IRE*, Vol. 10, No. 1, Feb. 1922, page 41.

Polyphase Rectification—H. R. Searing and M. H. Redmond—*Proceedings IRE*, Vol. 10, No. 1, Feb. 1922, page 52.

Notes on the Theory of Modulation—J. R. Carson—*Proceedings IRE*, Vol. 10, No. 1, Feb. 1922, page 57.

The Piezo-Electric Resonator—W. G. Cady—*Proceedings IRE*, Vol. 10, No. 2, April 1922, page 83.

A Study of the Oscillations Occurring in the Circuits of the Piotron—J. E. Ives and C. N. Hickman—*Proceedings IRE*, Vol. 10, No. 2, April 1922, page 115.

A Simple Method of Calculating Radiation Resistance—F. Cutting—*Proceedings IRE*, Vol. 10, No. 2, April 1922, page 129.

Mathematical Treatment of Rectification Phenomena—D. C. Prince—*Proceedings IRE*, Vol. 10, No. 5, Oct. 1922, page 393.

The Development of Tube Transmitters by the Telefunken Company—A. Meissner—*Proceedings IRE*, Feb. 1923, page 3.

[Continued on page 48]

Ingenious New Technical Methods

Presented in the hope that they will prove interesting and useful to you.

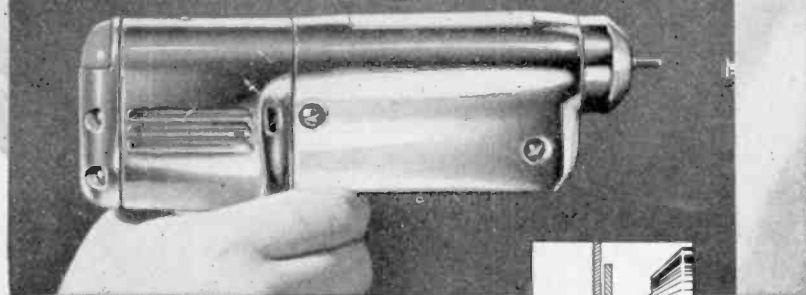

New Air Tool Drives "blind" Rivets Accurately... Automatically

Installing "blind" RIVNUTS quickly with precise, positive upset while working entirely from one side is now possible with the recently developed Auto RIV-Driver. Completely automatic, the tool runs a threaded mandrel into a Rivnut, upsets it, backs the mandrel out and stops the tool. Operators simply press a throttle; make no manual adjustments for any operation. Rivnuts are installed 6 to 8 times faster than formerly; rejects are almost completely eliminated.

The tool can be adjusted to upset at any depth required. Once set, adjustment is tamper-proof—every Rivnut is driven accurately and uniformly. An indicator on the tool handle lights when the upset is correct; does not light if Rivnut is improperly headed.

Powered by compressed air, the Auto RIV-Driver weighs just 4¼ pounds; is 9½ inches long; balanced for efficient handling by women operators.

You all know that our fighting men need the finest quality materials that we here at home can produce. That goes for Wrigley's Spearmint, Doublemint and "Juicy Fruit" chewing gum, too. Our stock pile of raw materials that goes into the making of Quality chewing gum is getting lower and lower. Until we can again build up our raw material inventory, we are sending all of our limited output of Quality chewing gum to our fighting men and women overseas, only.

You can get complete information from the Independent Pneumatic Tool Co., 600 W. Jackson Blvd., Chicago 6, Ill.

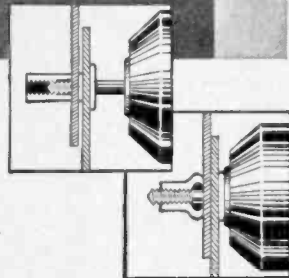

Rivnuts (mfd. by B. F. Goodrich Co.) are internally-threaded tubular rivets which can be installed "blind" while working entirely from one side of the job.

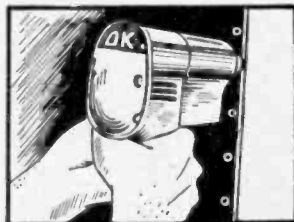

Automatic action, positive depth control and visual indicator assure correct and uniform installation of rivnuts with new Auto RIV-Driver

Y-117

Facts YOU SHOULD KNOW ABOUT RELAY SENSITIVITY

SO YOU would like a *sensitive* relay for that remote control circuit!

Sensitivity is important for many relay applications. And if that is *all* you want, there's no problem. It's easy to build a relay that will "operate" on a small amount of power.

But sensitivity without contact reliability is useless. So what you *really* want is a relay that is not only sensitive, but also has the contact pressure needed for reliability under actual service conditions.

Sensitivity and contact reliability are opposing factors. To get a high measure of both qualities in one relay calls for an exacting balance between electrical, mechanical and magnetic design factors. We've been building such relays for years — to meet hundreds of requirements, from complex telephone switching circuits to simple control functions on aircraft and radios.

Next time you need a *sensitive* relay, let the Automatic Electric field engineer show you how to get sensitivity *plus* contact reliability. No matter what the nature of your problem, there is an Automatic Electric relay that will give you both.

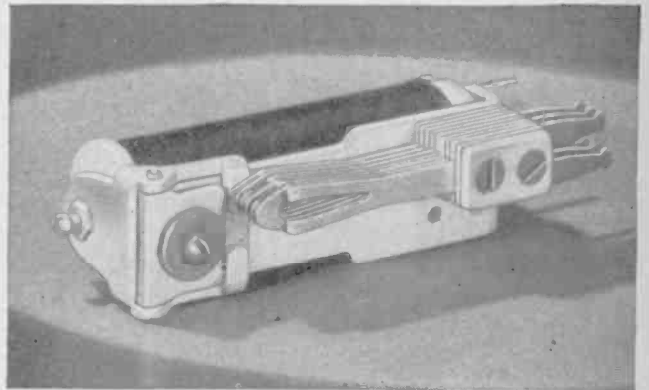

The Automatic Electric Class B Relay shown here combines high sensitivity and contact reliability. It has a highly efficient magnetic circuit, long wearing mechanical structure, independent twin contacts, and capacity for any number of springs up to 26. Contact pressures average 20 grams per contact. Compare this with "sensitive" relays having contact pressures of less than five grams.

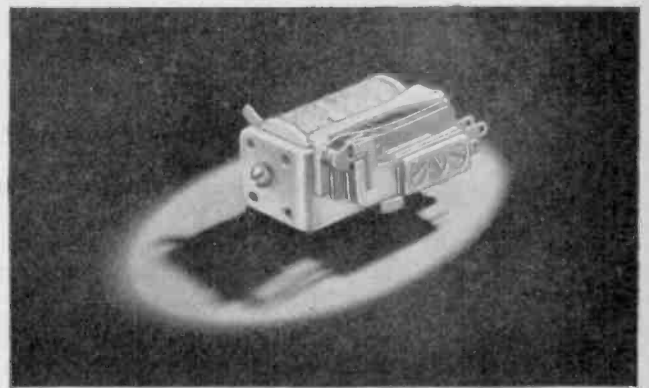

For high sensitivity and contact reliability in small space, your best bet is the Class S Relay shown here. Especially designed to meet the severe conditions of operation on fast modern aircraft, it is also recommended where space is at a premium. Because of the great demand for Class S Relays for vital war products, we urge that you avoid its use except where no other relay will serve.

Relays
AND OTHER CONTROL DEVICES
by AUTOMATIC
ELECTRIC



AUTOMATIC ELECTRIC SALES CORPORATION
1033 West Van Buren Street • Chicago 7, Ill.

In Canada: Automatic Electric
(Canada) Limited, Toronto

PARTS AND ASSEMBLIES FOR EVERY ELECTRICAL CONTROL NEED

RADIO BIBLIOGRAPHY

Description of the General Electric Company's Broadcasting Station at Schenectady, New York—W. R. G. Baker—*Proceedings IRE*, Aug. 1923, page 339.

Interference—R. H. Marriott—*Proceedings IRE*, Vol. 11, No. 4, Aug. 1923, page 375.

The Efficiency of Three Electrode Tubes Used for the Production of Continuous Waves in Radio Telegraphy; That Is, the Conversion of Direct Current into Alternating Current—A. Latour and H. Chireix—*Proceedings IRE*, Oct. 1923, page 551.

An Improved System of Modulation in Radio Telephony—C. A. Culver—*Proceedings IRE*, Vol. 11, No. 5, Oct. 1923, page 479.

Commercial Radio Tube Transmitters—W. R. G. Baker—*Proceedings IRE*, Dec. 1923, page 601.

Naval Aircraft Radio—T. Johnson, Jr.—*Proceedings IRE*, Vol. 8, No. 1, Feb. 1920, page 3.

The Radio Telegraphic Station at Rome (San Paolo)—B. Micchiardi, G. Pession, and G. Vallauri—*Proceedings IRE*, Vol. 8, No. 2, April 1920, page 142.

Calculation of Antenna Capacity—L. W. Austin—*Proceedings IRE*, Vol. 8, No. 2, April 1920, page 164.

The Use of Ground Wires at Remote Control Stations—A. H. Taylor and A. Crossley—*Proceedings IRE*, Vol. 8, No. 3, June 1920, page 171.

The Rome Radio Station of the Italian Navy—C. R. Elwell—*Proceedings IRE*, June 1920, page 193.

Trans-Oceanic Radio Communication—E. F. W. Alexanderson—*Proceedings IRE*, Vol. 8, No. 4, Aug. 1920, page 263.

Theory of Antenna Radiation—A. Press—*Proceedings IRE*, Vol. 8, No. 6, Dec. 1920, page 525.

A Brief Technical Description of the New San Diego, Pearl Harbor, and Cavite High Power Naval Radio Stations—L. F. Fuller—*Proceedings IRE*, Feb. 1919, page 11.

Electrical Oscillations in Antennas and Inductance Coils—J. M. Miller—*Proceedings IRE*, Vol. 7, No. 3, June 1919, page 299.

A Special Type of Quenched Spark Radio Transmitter—D. G. McCaa—*Proceedings IRE*, Aug. 1919, page 409.

Short Wave Reception and Transmission on Ground Wires (Subterranean and Submarine)—A. H. Taylor—*Proceedings IRE*, Vol. 7, No. 4, Aug. 1919, page 337.

Simultaneous Sending and Receiving—E. F. W. Alexanderson—*Proceedings IRE*, Vol. 7, No. 4, Aug. 1919, page 362.

Radio Telegraphy in Competition with Wire Telegraphy in Overland Work—R. B. Black—*Proceedings IRE*, Vol. 7, No. 4, Aug. 1919, page 363.

A Study of Electrostatically Coupled Circuits—W. O. Lytle—*Proceedings IRE*, Vol. 7, No. 4, Aug. 1919, page 427.

On the Multi-Section Quenched Gap—M. Shuleiken and I. Freiman—*Proceedings IRE*, Aug. 1919, page 417.

The Design of Poulsen Arc Converters for Radio Telegraphy—L. F. Fuller—*Proceedings IRE*, Oct. 1919, page 449.

Re-enforced Harmonics in High Power Arc Transmitters—F. A. Kolster—*Proceedings IRE*, Dec. 1919, page 648.

On the Electrical Operation and Mechanical Design of an Impulse Excitation Multi-Spark Group Radio Transmitter—B. Washington—*Proceedings IRE*, Dec. 1918, page 295.

The Vertical Grounded Antennas as a Generalized Besel's Antenna—A. Press—*Proceedings IRE*, Vol. 6, No. 6, Dec. 1918, page 317.

On the Possibility of the Tone Production by Rotary and Stationary Spark Gaps—H. Yagi—*Proceedings IRE*, Vol. 6, No. 6, Dec. 1918, page 323.

Some Additional Experiments on Impulse Excitation—E. W. Stone—*Proceedings IRE*, April 1917, page 133.

On the Poulsen Arc and Its Theory—P. O. Pedersen—*Proceedings IRE*, Aug. 1917, page 255.

An Automatic Transmitter for Distress Signals—C. M. Agner—*Proceedings IRE*, Vol. 5, No. 5, Oct. 1917, page 353.

The Coupled Circuit by the Method of Generalized Angular Velocities—V. Bush—*Proceedings IRE*, Vol. 5, No. 5, Oct. 1917, page 447.

The Effect of Commercial Conditions and Spark Transmitter Construction—J. Barth—*Proceedings IRE*, Oct. 1917, page 331.

Some Experiments with Long Electrical

[Continued on page 50]



Electro-Voice DIFFERENTIAL MICROPHONE Model T-45 is its U.S. ARMY DESIGNATION

Developed by Electro-Voice engineers in collaboration with the Fort Monmouth Signal Laboratory, this Differential "Lip Mike" carries the voice clearly and distinctly above the roar of battle. Ambient sounds and reverberation are reduced to negligible levels.

- ◆ Frequency response substantially flat from 200-4000 cps.
- ◆ Low harmonic distortion
- ◆ Cancellation of ambient noise, but normal response to user's voice
- ◆ Self-supporting, to free both hands of the operator
- ◆ Uniform response in all positions
- ◆ Usable when gas mask, dust respirator or oxygen mask is required
- ◆ Unaffected by temperature cycles from -40° F. to $+185^{\circ}$ F.
- ◆ Ability to withstand complete immersion in water
- ◆ Physical strength to withstand 10,000 drops
- ◆ Weight, including harness, cord and plug, less than 2 ounces.

Electro-Voice MICROPHONES

Our full line includes Carbon, Dynamic and Velocity models . . . all at popular prices . . . for public address, industrial sound, sound recording and speech transmission applications. Consult your local radio parts jobber.

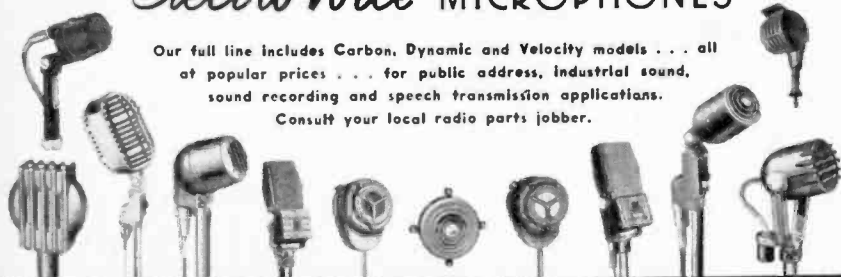

ELECTRO-VOICE MANUFACTURING CO., INC. • 1239 SOUTH BEND AVENUE • SOUTH BEND 24, INDIANA
Export Division: 13 East 40th Street, New York 16, N. Y. — U. S. A. Cables: ARLAB

FOIL THE SABOTEURS

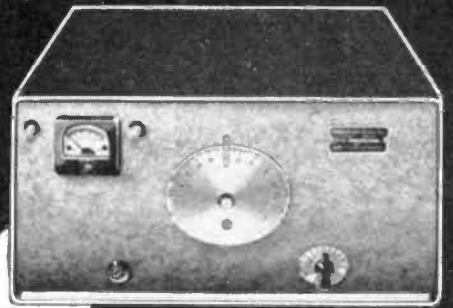

Give critical plants the protection of Browning Signal System with its balanced-capacitance electronic circuit, which saturates vulnerable areas and releases guards for productive duty. Pre-

Pearl Harbor installations have proved efficient, dependable, economical.

Browning Frequency Meters are accurate to .005%. Pre-check public utility and other emergency radio systems. Assure signal clarity.

ILLUSTRATED LITERATURE UPON REQUEST



BROWNING
LABORATORIES, INCORPORATED
WINCHESTER, MASSACHUSETTS

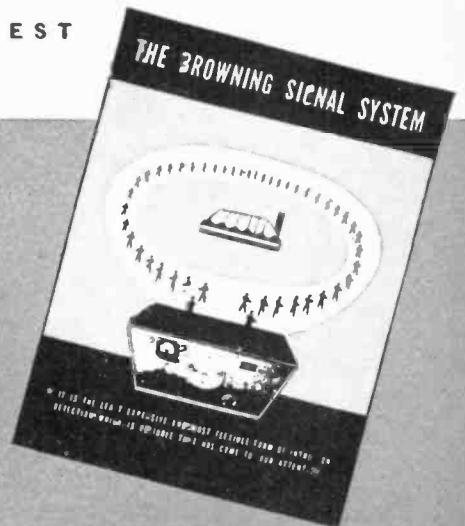

RADIO BIBLIOGRAPHY

Conductors—J. H. Morecroft—*Proceedings IRE*, Vol. 5, No. 6, Dec. 1917, page 389.

Distributed Inductance of Vertical Grounded Antennas—A. Press—*Proceedings IRE*, Vol. 5, No. 6, Dec. 1917, page 413.

On the Phenomena in Resonance Transformers—H. Yagi—*Proceedings IRE*, Vol. 5, No. 6, Dec. 1917, page 433.

The Use of Multiphase Radio Transmitters—W. C. Woodland—*Proceedings IRE*, Feb. 1916, page 11.

A Null Method of Measuring Energy Consumption in a Complex Circuit—A. S. Kuhn—*Proceedings IRE*, Feb. 1916, No. 1,

page 33.

The Darien Radio Station of the U. S. Navy (Panama Canal Zone)—Lt. R. C. Crenshaw—*Proceedings IRE*, Feb. 1916, page 35.

Low-Frequency High Power Broadcasting as Applied to National Coverage in the United States—W. H. Wenstrom—*Proceedings IRE*, Vol. 19, No. 6, June 1931, page 971.

On the Calculation of Radiation Resistance of Antennas and Antenna Combinations—R. Bechmann—*Proceedings IRE*, Vol. 19, No. 8, Aug. 1931, page 1471.

The Adjustment of the Multivibrator for

Frequency Division—V. J. Andrew—*Proceedings IRE*, Vol. 19, No. 11, Nov. 1931, page 1911.

New Methods of Frequency Control Employing Long Lines—J. W. Conklin, J. L. Finch and C. W. Hansell—*Proceedings IRE*, Vol. 19, No. 11, Nov. 1931, page 1918.

The Broadcast Installations in the New "House of Radio"—G. Lubszynski and K. Hoffmann—*Proceedings IRE*, Vol. 19, No. 11, Nov. 1931, page 1955.

Vacuum Tubes as High-Frequency Oscillators—E. D. McArthur and E. E. Spitzer—*Proceedings IRE*, Vol. 19, No. 11, Nov. 1931, page 1971.

Constant Frequency Oscillators—F. B. Llewellyn—*Proceedings IRE*, Vol. 19, No. 12, Dec. 1931, page 2063.

A Recent Development in Vacuum Tube Oscillator Circuits—J. B. Dow—*Proceedings IRE*, Vol. 19, No. 12, Dec. 1931, page 2095.

Amplitude, Phase, and Frequency Modulation—H. Roder—*Proceedings IRE*, Vol. 19, No. 12, Dec. 1931, page 2145.

Some Developments in Broadcast Transmitters—I. J. Kaar and C. J. Burnside—*Proceedings IRE*, Vol. 18, No. 10, Oct. 1930, page 1623.

On Magnetron Oscillation of a New Type—K. Okabe—*Proceedings IRE*, Vol. 18, No. 10, Oct. 1930, page 1748.

The Transatlantic Short-Wave Transmitters—E. B. Ferrell—*Bell Lab. Record*, Vol. VII, No. 12, Aug. 1929, page 497.

Transmitting Station at Lawrenceville, N. J.—M. E. Fultz—*Bell Lab. Record*, Vol. VII, No. 12, Aug. 1929, page 489.

Water Cooling for Radio—J. O. Gargan—*Bell Lab. Record*, Vol. VI, No. 1, March 1928, page 211.

Piezo-Electric Crystal-Controlled Transmitters—A. Crossley—*Proceedings IRE*, Vol. 15, No. 1, Jan. 1927, page 9.

Simultaneous Production of a Fundamental and a Harmonic in a Tube Generator—H. J. Walls—*Proceedings IRE*, Vol. 15, No. 1, Jan. 1927, page 37.

Piezo-Electric Crystals at Radio Frequencies—A. Meissner—*Proceedings IRE*, Vol. 15, No. 4, April 1927, page 281.

Power Rating of Broadcasting Transmitters—O. M. Glunt—*Bell Lab. Record*, Vol. V, No. 3, Nov. 1927, page 69.

The Fifty Kilowatt Radio Transmitter—A. W. Kishpaugh—*Bell Lab. Record*, Vol. V, No. 3, Nov. 1927, page 71.

Some Studies in Radio Broadcast Transmission—R. Bown, D. K. Martin, and R. K. Potter—*Proceedings IRE*, Vol. 14, No. 1, Feb. 1926, page 57.

Sleet Removal from Antennas—J. H. Shannon—*Proceedings IRE*, Vol. 14, No. 2, April 1926, page 181.

One-KW Radio Transmitter for Broadcasting—A. W. Kishpaugh—*Bell Lab. Record*, Vol. II, No. 2, April 1926, page 60.

Choice of Power for a Radio Station—N. Tsiklinsky and V. I. Volynkin—*Proceedings IRE*, June 1926, page 381.

"KDKA"—D. G. Little and R. L. Davis—*Proceedings IRE*, Vol. 14, No. 4, Aug. 1926, page 479.

Recent Developments in Vacuum Tube Transmitters—B. R. Cummings—*Proceedings IRE*, Feb. 1925, page 49.

[Continued on page 52]



FOR EVERY WAR PURPOSE NOW...
For you when possible!

TRANSMITTING TUBES
CATHODE RAY TUBES
SPECIAL PURPOSE TUBES

KEN-RAD
EXECUTIVE OFFICES
OWENSBORO, KENTUCKY
EXPORTS 11 MOORE STREET NEW YORK

RECEIVING TUBES
INCANDESCENT LAMPS
FLUORESCENT LAMPS

Eimac Vacuum Pump

To create the nearly perfect vacuum within Eimac tubes and put vacuum pumping on a mass production basis, Eimac Engineers developed a whole new vacuum technique and much special equipment.

One of the devices resulting from these years of research and development is the Eimac HV-1 Diffusion Pump together with the special vaporizing oil which it requires.

Today this pump is being made available to manufacturers and research laboratories throughout the world. You can obtain full information and technical data without cost or obligation by writing direct to the San Bruno plant address below.

This Eimac HV-1 pump is one good reason why Eimac tubes are unconditionally guaranteed against premature failures which are caused by gas released internally. This reason plus outstanding performance, great stamina and others have made Eimac tubes first choice of leading Engineers throughout the world.

Follow the leaders to

Eimac
TUBES

PART NO	QTY	RECD	DESCRIPTION
D-1	1		1/8" BNC 1/2" L N STEEL CAPSCREW
D-2	2		1/8" BNC HEX NUT
D-3	1		3/16" BNC 1/2" L N STEEL CAPSCREW
D-4	1		3/16" BNC HEX NUT
D-5	1		3/16" BNC 1/2" L N STEEL CAPSCREW
D-6	1		3/16" BNC HEX NUT
D-7	1		3/16" BNC 1/2" L N STEEL CAPSCREW
D-8	1		3/16" BNC HEX NUT
D-9	1		3/16" BNC 1/2" L N STEEL CAPSCREW
D-10	1		3/16" BNC HEX NUT
D-11	1		3/16" BNC 1/2" L N STEEL CAPSCREW
D-12	1		3/16" BNC HEX NUT
D-13	1		3/16" BNC 1/2" L N STEEL CAPSCREW
D-14	1		3/16" BNC HEX NUT
D-15	1		3/16" BNC 1/2" L N STEEL CAPSCREW
D-16	1		3/16" BNC HEX NUT
D-17	1		3/16" BNC 1/2" L N STEEL CAPSCREW
D-18	1		3/16" BNC HEX NUT
D-19	1		3/16" BNC 1/2" L N STEEL CAPSCREW
D-20	1		3/16" BNC HEX NUT
D-21	1		3/16" BNC 1/2" L N STEEL CAPSCREW
D-22	1		3/16" BNC HEX NUT

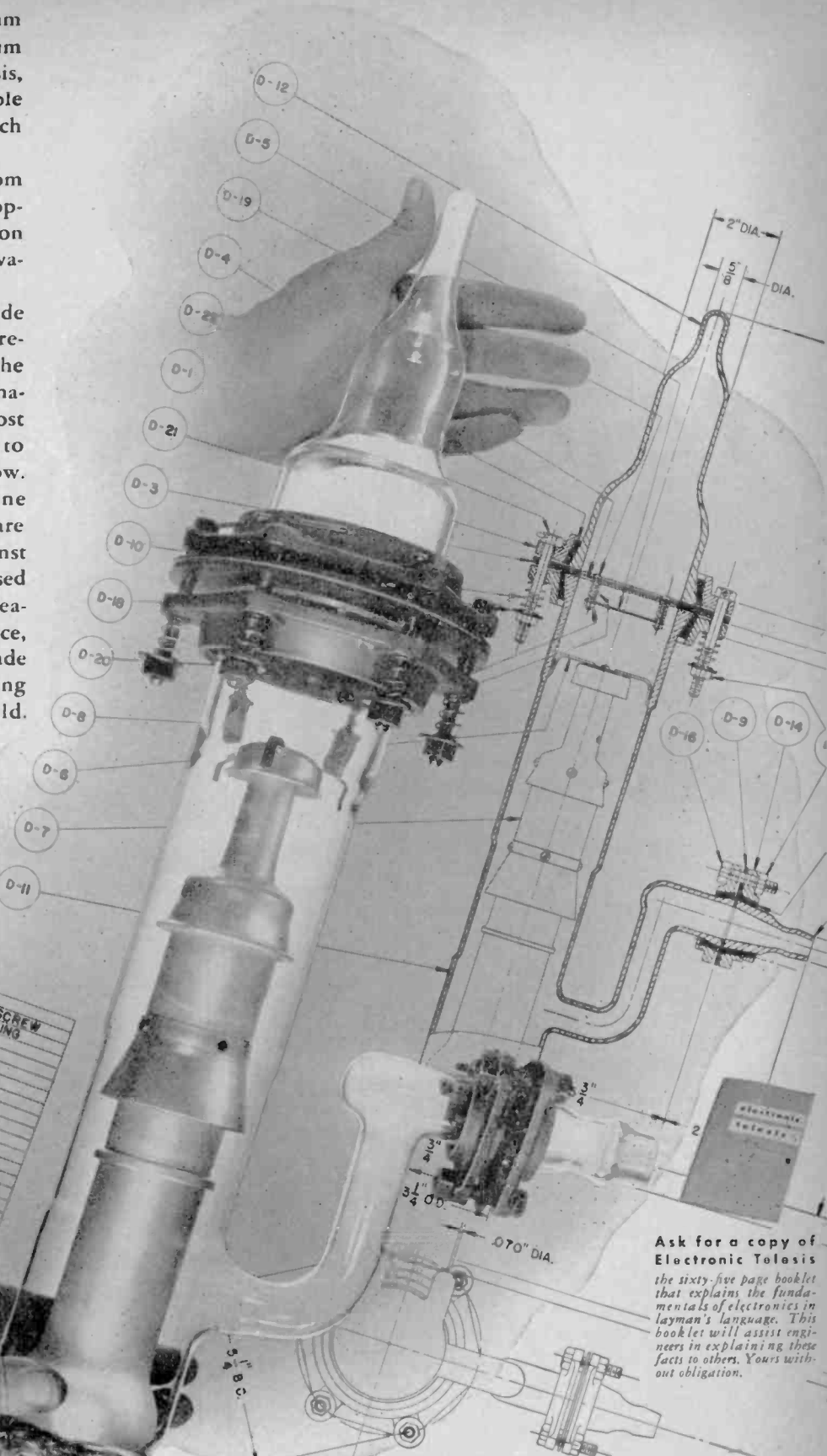

Ask for a copy of **Electronic Telesis** the sixty-five page booklet that explains the fundamentals of electronics in layman's language. This booklet will assist engineers in explaining these facts to others. Yours without obligation.

EITEL-McCULLOUGH, INC., 816 San Mateo Avenue, SAN BRUNO, CALIFORNIA
Plants located at: San Bruno, California and Salt Lake City, Utah

Export Agents: **FRAZAR & HANSEN, 301 Clay Street, San Francisco, California, U. S. A.**

DIRECTIONAL ARRAYS

[Continued from page 23]

the maximum value of this ratio occurs where $\sin 2\pi/\lambda (l-d) \rightarrow$ unity, where l = total length and d = distance from the sending end. The minimum value then occurs when $\cos 2\pi/\lambda (l-d) \rightarrow$ unity.

From the relationship of the current and impedance functions of transmission lines we may obtain:

$$I_{min}/I_{max} \cong R_R/Z_0 \dots \dots (18)$$

where modified to illustrate the relationship in a half-wave radiator which we are discussing. R_R is the resistive component of Z_R and may be seen to be referred to the point of maximum current.

Thus equation (18) and either equation (15), (16), or (17) may be used to illustrate the relationship of radiation resistance to the characteristic impedance of the antenna

For example, assuming a tower of the type of Fig. 11-A, 400 feet high and 8 feet across at the base (therefore 4 feet radius). From equation (15)

$$Z_0 = 120 \log 400/4 = 120 \log 100 = 240 \text{ ohms}$$

The image antenna now gives a free space $Z_0 = 480$ ohms. Assume the ratio I_{min}/I_{max} to be measured at the operating frequency at 0.25. Then, from equation (18)

$$0.25 = R_R/480 \\ R_R = 120 \text{ ohms.}$$

Conclusion

As is apparent to the reader, no new theory has been contributed to the field of antenna study in this paper. The method of attack, due to its simplicity, is too awkward for use under practical conditions. It is hoped, however, that due to this very character, the more general reader will have gained a better picture physically and mathematically of what happens in an antenna and a directional array. The use of equivalents and analogs for antenna array analysis should lead into further interesting possibilities.

DX VICTOIRETTES

The DX Victorettes, an organization of girl war workers in the DX Crystal Company plants in Chicago, raised three hundred dollars by holding dances and parties. The girls donated the money to the "smokes" and travel funds for wounded veterans at the Hines Hospital, Chicago. Irv. Kupcinet, Chicago Daily Times columnist, presented the check to C. G. Beck, Hines Hospital Manager.

BIBLIOGRAPHY

[Continued from page 50]

Recent Investigation on the Propagation of Electro-Magnetic Waves—M. Baeumler—*Proceedings IRE*, Vol. 13, No. 1, Feb. 1925, page 5.

Production of Single Side-Band for Trans-Atlantic Radio Telephony—R. A. Heising—*Proceedings IRE*, Vol. 13, No. 3, June 1925, page 291.

Power Amplifiers in Trans-Atlantic Radio Telephony—E. A. Oswald and J. C. Schieleng—*Proceedings IRE*, June 1925, page 313.

Re-Radiation from Tuned Antenna Systems—H. C. Forbes—*Proceedings IRE*, Vol. 13, No. 3, June 1925, page 363.

Generation of Polyphase Oscillations by Means of Electron Tubes—R. Mesny—*Proceedings IRE*, Vol. 13, No. 4, Aug. 1925, page 471.

Transmitting Equipment for Radio Telephone Broadcasting—E. L. Nelson—*Proceedings IRE*, Oct. 1924, page 533.

The Cape Cod Marine System of the Radio Corp. of America—F. H. Kroger—*Proceedings IRE*, Vol. 12, No. 3, June 1924, page 243.

Short-Wave Radio Broadcasting—F. Conrad—*Proceedings IRE*, Dec. 1924, page 723.

The High Power Station at Malabar, Java—C. De Groot—*Proceedings IRE*, Dec. 1924, page 693.

On the Radiation Resistance of a Simple Vertical Antenna at Wave Lengths Below the Fundamental—S. Ballantine—*Proceedings IRE*, Vol. 12, No. 6, Dec. 1924, page 823.

On the Optimum Transmitting Wave Length for a Vertical Antenna Over Perfect Earth—S. Ballantine—*Proceedings IRE*, Vol. 12, No. 6, Dec. 1924, page 833.

Frequencies and Damping Factors of Coupled Circuits—L. Cohen—*Proceedings IRE*, Vol. 9, No. 2, April 1921, page 150.

Recent Progress in Radio Communication in Germany and Austria—E. Nesper—*Proceedings IRE*, Vol. 9, No. 3, June 1921, page 183.

On the Poulsen Arc in Coupled Circuits—P. O. Pedersen—*Proceedings IRE*, Vol. 9, No. 3, June 1921, page 228.

The Equivalent Circuit of the Vacuum Tube Modulator—J. R. Carson—*Proceedings IRE*, Vol. 9, No. 3, June 1921, page 243.

Vacuum Tube Amplifiers in Parallel—R. V. L. Hartley—*Proceedings IRE*, Vol. 9, No. 3, June 1921, page 250.

Modulation in Radio Telephony—R. A. Heising—*Proceedings IRE*, Vol. 9, No. 4, Aug. 1921, page 305.

Some Improvements in the Poulsen Arc—P. O. Pedersen—*Proceedings IRE*, Vol. 9, No. 5, Oct. 1921, page 434.

The Development of Tube Transmitters by the Telefunken Company—A. Meissner—*Proceedings IRE*, Vol. 10, No. 1, Feb. 1922, page 3.

A Magnetic Amplifier for Radio Telephony—E. F. W. Alexanderson and A. P. Nixdorf—*Proceedings IRE*, Vol. 4, No. 2, April 1916, page 101.

The Theory and Design of Radio-Telegraphic Transformers—F. Cutting—*Pro-*

[Continued on page 54]

Products of "MERIT" means Fine Radio Parts

... PARTS manufactured exactly to the most precise specifications.

Long manufacturers of component radio parts, MERIT entered the war program as a complete, co-ordinated manufacturing unit of skilled radio engineers, experienced precision workmen and skilled operators with the most modern equipment.

MERIT quickly established its ability to understand difficult requirements, quote intelligently and produce in quantity to the most exacting specifications.

Transformers—Coils—Reactors—Electrical Windings of All Types for the Radio and Radar Trade and other Electronic Applications.

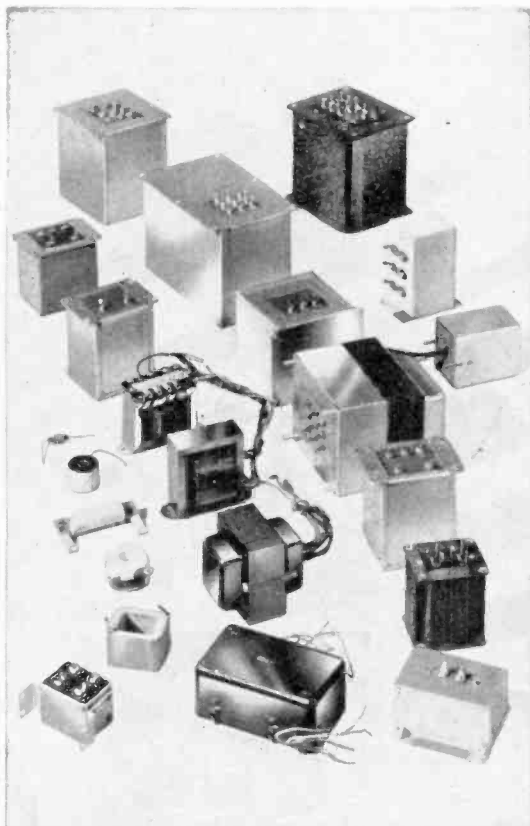

MERIT COIL & TRANSFORMER CORP.
311 North Desplaines St. CHICAGO 6, ILL.

**"HERE'S A
DEPENDABLE SOURCE
OF LABORATORY
D. C. POWER..."**



The HARVEY Regulated Power Supply 106 PA

You'll find it ideal for operation with pulse generators, measurement equipment, constant frequency applicators, amplifiers and any other equipment requiring a constant flow of D. C. voltage.

Designed to operate from 115 volts A. C., the HARVEY 106 PA has a D. C. voltage output variable from between 200 to 300 volts and accurately controllable to within one per cent. A model of efficiency and convenience, it has separate fuses on each

transformer primary as well as the D. C. output circuit: pilot lights on each switch; a D. C. voltmeter for measuring output voltage and a handy two-prong plug or binding posts to permit easy hook-up.

For complete information on this precision-built, thoroughly dependable source of constant voltage, write for the new HARVEY Regulated Power Supply bulletin. Address your requests for this useful new bulletin to



HARVEY RADIO LABORATORIES, INC.
454 CONCORD AVENUE • CAMBRIDGE 38, MASS.

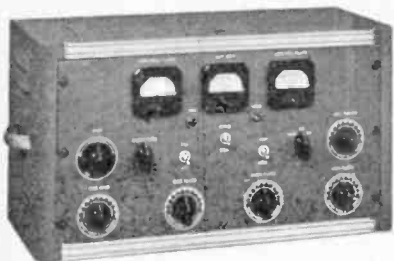

HARVEY UHX-25

A 25-Watt
General Purpose
Radio Telephone
Transmitter

Available for operation between 1.5 M. C. and 30 M. C.

HARVEY "AMPLI-STRIP"



FOR I-F AND AUDIO
AMPLIFICATION



featuring . . .

- Standard laboratory instrument design and workmanship.
- Wheatstone Bridge Type RN-1. Four resistance dials. Nine positions each. 9 X 1, 9 X 10, 9 X 100, 9 X 1000 ohms, with decade multiplying dials.
- Ratio resistance guaranteed to plus/minus .05%. Resistance coils to 1%.
- Moving coil galvanometer. Sensitivity of 1 microampere per division. 4½ v. internal battery. External battery and galvanometer connections.
- Resistance Decades Type DR. .9 to 999,999 ohms. Accuracy plus/minus .1%.
- Manganin wire coils. Bifilar-wound on ceramic tubes.
- Self-cleaning multi-blade phosphor-bronze spring wiper switches.
- Standard walnut cases.

BRIDGES and DECADE BOXES

● Large-scale requirements on the part of a major Government contractor for equipment "equal to and interchangeable with" present D.C. Wheatstone Bridges and Resistance Decades led us to set up for line production of such instruments. The result is that we can promise prompt delivery because we are in continuous production on such equipment.

We also offer Direct-Reading Capacitance Decade Boxes. 1% or .5% accuracy. Incorporating paper or mica dielectric capacitors. Available in .01, .001 and .0001 mfd. steps. Total capacities of .111, 1.11 and 11.1 mfd.

NEW CATALOG . . .

Covers essential laboratory and production-test instruments. Rugged, practical, accurate, moderate in cost. Write for your copy. Consult us regarding your instrumentation problems.

Industrial



PLANT and OFFICES:

17 POLLOCK AVENUE

JERSEY CITY 5, N. J.

Instruments

BIBLIOGRAPHY

[Continued from page 52]

ceedings IRE, Vol. 4, No. 2, April 1916, page 157.

Experiments at the U. S. Naval Radio Station, Darien, Canal Zone—L. W. Austin—*Proceedings IRE*, Vol. 4, No. 3, June 1916, page 251.

The Mechanism of Radiation and Propagation in Radio Communication—F. Lowenstein—*Proceedings IRE*, Vol. 4, No. 3, June 1916, page 271.

Amplitude Relations in Coupled Circuits—E. L. Chaffee—*Proceedings IRE*, Vol. 4, No. 3, June 1916, page 283.

An Impulse Excitation Transmitter—E. W. Stone—*Proceedings IRE*, June 1916, page 233.

Arlington Radio Station and Its Activities in the General Scheme of Naval Radio Communication—W. H. G. Bullard—*Proceedings IRE*, Vol. 4, No. 5, Oct. 1916, page 421.

A Few Experiments with Ground Antennas—L. F. Fuller—*Proceedings IRE*, Vol. 4, No. 5, Oct. 1916, page 455.

The Effect of the Spark on the Oscillation of an Electric Circuit—J. S. Stone—*Proceedings IRE*, Vol. 4, No. 5, Oct. 1916, page 483.

On the Determination of the Energy Losses in a Radio Telegraph Transmitter—B. Washington and P. H. Royster—*Proceedings IRE*, Dec. 1916, page 499.

Resonance Phenomena in the Low Frequency Circuit of Radio Transmitters—H. E. Hallborg—*Proceedings IRE*, Vol. 3, No. 2, June 1915, page 105.

Design and Construction of Guy-Supported Towers for Radio Telegraphy—R. A. Weagant—*Proceedings IRE*, Vol. 3, No. 2, June 1915, page 135.

Wooden Lattice Masts—C. F. Elwell—*Proceedings IRE*, Vol. 3, No. 2, June 1915, page 161.

The Effectiveness of the Ground Antenna in Long Distance Reception—R. B. Woolverton—*Proceedings IRE*, Vol. 3, No. 4, Dec. 1915, page 371.

The Pupin Theory of Asymmetrical Rotors in Unidirectional Fields (with special reference to the theory of the Goldschmidt alternator)—B. Liebowitz—*Proceedings IRE*, Vol. 3, No. 4, Dec. 1915, page 385.

The Design of the Audio Frequency Circuit of Quenched Spark Transmitters—J. Weinberger—*Proceedings IRE*, Dec. 1915, page 377.

The Goldschmidt System of Radio Telegraphy—E. E. Mayer—*Proceedings IRE*, Vol. 2, No. 1, March 1914, page 69.

The Operating Characteristics of a Three-Phase 500 Cycle Quenched Spark Transmitter—E. J. Simon and L. L. Israel—*Proceedings IRE*, Sept. 1914, Vol. 2, No. 3, page 217.

The "Hytone" Radio Telegraph Transmitter—M. Eastham—*Proceedings IRE*, Vol. 2, No. 4, Dec. 1914, page 253.

The Resistance of the Spark and Its Effect on the Oscillation of Electrical Oscillators—J. S. Stone—*Proceedings IRE*, Vol. 2, No. 4, Dec. 1914, page 207.

A Discussion on Experimental Tests of the Radiation Law for Radio Oscillators—M. I. Pupin—*Proceedings IRE*, Vol. 1, No. 1, Jan. 1913, page 3.

High Tension Insulators for Radio-Communication—S. M. Hills—*Proceedings*

IRE, Vol. 1, No. 1, Jan. 1913, page 14.

Recent Developments in the Work of the Federal Telegraph Co.—L. de Forest—*Proceedings IRE*, Vol. 1, No. 1, Jan. 1913, page 53.

Radio Operation by Steamship Companies—R. H. Marriott—*Proceedings IRE*, Vol. 1, No. 2, April 1913, page 3.

The Effects of Distributed Capacity of Coils Used in Radio-Telegraphic Circuits—F. A. Kolster—*Proceedings IRE*, Vol. 1, No. 2, April 1913, page 19.

The High Power Telefunken Radio Station at Sayville, Long Island—F. Van Der Woude and A. Seelig—*Proceedings IRE*, Vol. 1, No. 3, July 1913, page 18.

Some Recent Radio Sets of the Marconi Wireless Telegraph Company of America—R. A. Weagant—*Proceedings IRE*, Dec. 1913, page 43.

The Mathematics of the Physical Properties of Crystals—W. L. Bond—*Bell System Tech. Journal*, Vol. XXII, Jan. 1943, page 1.

A Mineral Survey for Piezo-Electric Materials—L. L. Bond—*Bell System Tech. Journal*, Vol. XXII, July 1943, page 145.

Quartz Crystal Applications—W. P. Mason—*Bell System Tech. Journal*, Vol. XXII, July 1943, page 178.

Methods for Specifying Quartz Crystal Orientation and Their Determination by Optical Means—W. L. Bond—*Bell System Tech. Journal*, Vol. XXII, July 1943, page 224.

Use of X-Rays for Determining the Orientation of Quartz Crystals—W. L. Bond and E. J. Armstrong—*Bell System Tech. Journal*, Vol. XXII, Oct. 1943, page 293.

Constant Frequency Oscillators—F. B. Llewellyn—*Bell System Tech. Journal*, Vol. XI, Jan. 1932, page 67.

Ultra-Short Wave Propagation—J. C. Schelleng, C. R. Burrows and E. B. Ferrell—*Bell System Tech. Journal*, Vol. XII, April 1933, page 125.

Some Results of a Study of Ultra-Short Wave Transmission Phenomena—E. C. Englund, A. B. Crawford and W. W. Mumford—*Bell System Tech. Journal*, Vol. XII, April 1933, page 197.

New Results in the Calculation of Modulation Products—W. R. Bennett—*Bell System Tech. Journal*, Vol. XII, April 1933, page 228.

Stabilized Feedback Amplifiers—H. S. Black—*Bell System Tech. Journal*, Vol. XIII, Jan. 1934, page 1.

Vacuum Tube Electronics at Ultra-High Frequencies—F. B. Llewellyn—*Bell System Tech. Journal*, Vol. XIII, Jan. 1934, page 59.

The Effect of Background Noise in Shared Channel Broadcasting—C. B. Aiken—*Bell System Tech. Journal*, Vol. XIII, July 1934, page 333.

A Theory of Scanning to the Characteristics of the Transmitted Signal in Telephotography and Television—P. Mertz and F. Gray—*Bell System Tech. Journal*, Vol. XIII, July 1934, page 464.

Horizontal Rhombic Antennas—E. Bruce, A. C. Beck and L. R. Lowry—*Bell System Tech. Journal*, Vol. XIV, Jan. 1935, page 135.

Ultra-Short-Wave Propagation: Mobile Urban Transmission Characteristics—C. R. Burrows, L. E. Hunt and A. Decino—*Bell System Tech. Journal*, Vol. XIV, April 1935, page 253.

Further Results of a Study of Ultra-Short-

[Continued on page 56]



The Famous Three!

Tinker, Evers and Chance were famous for Stamina, Efficiency and Fine Performance. So are all RACON Products!

There's a RACON speaker, horn and driving unit for every conceivable sound distribution application. Only RACON can supply, when needed, another famous three-in-one combination — Weatherproof, Stormproof. Acoustic Material which is impervious to any weather condition and prevents resonant effects.

Now that industrial war plants can obtain sound installations, remember that RACON's should be used to afford peak efficiency.

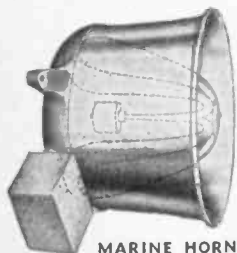

MARINE HORN



RE-ENTRANT TRUMPETS



P.M. UNITS

MARINE HORN SPEAKERS, approved by the U. S. Coast Guard, may be used as both speaker and microphone. Available in several sizes.

RE-ENTRANT TRUMPETS, compact, of the double re-entrant type, afford long air-column in small space; deliver highly concentrated sound over long distances.

P.M. HORN UNITS are available in operating capacities of 5 to 50 watts.

RACON ELECTRIC CO. 52 E. 19th ST., N. Y.

RACON



Stepping up to
10 MILLION
VOLTS

• Charged in parallel, discharged in series, these capacitors provide for voltages up to 10,000,000 and over. Individual units are rated from 50,000 to 150,000 volts D.C. Choice of capacitances, from .001 to .1 mfd.

Originally designed for certain deep penetration X-ray and impulse generator applications, Aerovox Type '26 capacitors may be used for radio and electronic applications requiring exceptionally high operating voltages. Multi-layer paper sections; oil-impregnated, oil-filled; housed in sturdy tubular bakelite cases. Choice of metal cap terminals facilitate stack mounting and connections. Sections of matched capacitance insuring uniform voltage gradient throughout length of capacitor.

• DATA . . .

New catalog, listing an outstanding line of heavy-duty capacitors for radio, electronic and industrial functions, sent on request to engineers and others engaged in radio and electronic work. Write on business stationery.



INDIVIDUALLY TESTED

AEROVOX CORP., NEW BEDFORD, MASS., U. S. A.

In Canada: AEROVDX CANADA LTD., HAMILTON, ONT.

Export: 13 E. 40 ST., NEW YORK 16, N. Y. Cable: 'ARLAB'

BIBLIOGRAPHY

[Continued from page 54]

Wave Transmission Phenomena—C. R. Englund, A. B. Crawford and W. W. Mumford—*Bell System Tech. Journal*, Vol. XIV, July 1935, page 369.

Radio Propagation Over Spherical Earth—C. R. Burrows—*Bell System Tech. Journal*, Vol. XIV, July 1935, page 477.

A Single-Sideband Short-Wave System for Transatlantic Telephony—F. A. Polkinghorn and N. F. Schlaack—*Bell System Tech. Journal*, Vol. XIV, July 1935, page 489.

An Unattended Ultra-Short-Wave Radio Telephone System—N. F. Schlaack and F. A. Polkinghorn—*Bell System Tech. Journal*, Vol. XIV, July 1935, page 534.

Transatlantic Long-Wave Transmission—A. Bailey and H. M. Thomson—*Bell System Tech. Journal*, Vol. XIV, Oct. 1935, page 680.

Marine Radio Telephone Service for Boston Harbor—F. A. Gifford and R. B. Meader—*Bell System Tech. Journal*, Vol. XIV, Oct. 1935, page 702.

Harbor Craft Ship-to-Shore Radio Telephone Service in Puget Sound Area—E. B. Hansen—*Bell System Tech. Journal*, Vol. XIV, Oct. 1935, page 708.

Ship Sets for Harbor Ship-to-Shore Service—H. N. Willets—*Bell System Tech. Journal*, Vol. XIV, Oct. 1935, page 713.

On the Correlation of Radio Transmission with Solar Phenomena—A. M. Skellett—*Bell System Tech. Journal*, Vol. XV, Jan. 1936, page 157.

Earth Resistivity and Geological Structure—R. H. Card—*Bell System Tech. Journal*, Vol. XV, Jan. 1936, page 167.

The Reliability of Short-Wave Radio Telephone Circuits—R. K. Potter and A. C. Peterson, Jr.—*Bell System Tech. Journal*, Vol. XV, April 1936, page 181.

Hyper-Frequency Wave Guides—General Considerations and Experimental Results—G. C. Southworth—*Bell System Tech. Journal*, Vol. XV, April 1936, page 284.

Hyper-Frequency Wave Guides—Mathematical Theory—J. R. Carson, S. P. Mead and S. A. Schelkunoff—*Bell System Tech. Journal*, Vol. XV, April 1936, page 310.

Oscillations in Systems with Non-Linear Reactance—R. V. L. Hartley—*Bell System Tech. Journal*, Vol. XV, July 1936, page 424.

Radio Propagation Over Plane Earth—Field Strength Curves—C. R. Burrows—*Bell System Tech. Journal*, Vol. XVI, Jan. 1937, page 45, and Oct. 1937, page 574.

A Multiple Unit Steerable Antenna for Short-Wave Reception—H. T. Friis and C. B. Feldman—*Bell System Tech. Journal*, Vol. XVI, July 1937, page 337.

Variable Frequency Electric Circuit Theory with Application to the Theory of Frequency-Modulation—J. R. Carson and T. C. Fry—*Bell System Tech. Journal*, Vol. XVI, Oct. 1937, page 513.

Stabilized Feedback Oscillators—G. H. Stevenson—*Bell System Tech. Journal*, Vol. XVII, July 1938, page 458.

Equivalent Modulator Circuits—E. Peterson and L. W. Hussey—*Bell System Tech. Journal*, Vol. XVIII, Jan. 1938, page 32.

The Production of Ultra-High-Frequency Oscillations by Means of Diodes—F. B. Llewellyn and A. E. Bowen—*Bell System*

Tech. Journal, Vol. XVIII, April 1939, page 280.

Frequency-Modulation: Theory of the Feedback Receiving Circuit—J. R. Carson—*Bell System Tech. Journal*, Vol. XVIII, July 1939, page 395.

The Application of Negative Feedback to Frequency-Modulation Systems—J. G. Chaffee—*Bell System Tech. Journal*, Vol. XVIII, July 1939, page 404.

Effect of the Quadrature Component in Single Sideband Transmission—H. Nyquist and K. W. Pfeiffer—*Bell System Tech. Journal*, Vol. XIX, Jan. 1940, page 74.

Electrical Wave Filters Employing Crystals with Normal and Divided Electrodes—W. P. Mason and R. A. Sykes—*Bell System Tech. Journal*, Vol. XIX, April 1940, page 221.

Manufacture of Quartz Crystal Filters—G. K. Burns—*Bell System Tech. Journal*, Vol. XIX, Oct. 1940, page 516.

Computing Antenna Height—C. C. Jinks—*Electronics*, Vol. XI, July 1938, page 30.

Radial Ground System Chart—G. H. Brown—*Electronics*, Vol. XI, Jan. 1938, page 33.

Rotatable Antenna at PCJ—D. J. Furin—*Electronics*, Vol. XI, Feb. 1938, page 30.

WBZ Engineers Search Out New Home with a Balloon—*Electronics*, Vol. XI, July 1938, page 36.

WTAR Directional Array—G. H. Brown—*Electronics*, Vol. XI, Jan. 1938, page 38.

Solving a Rectifier Problem—R. Lee—*Electronics*, Vol. XI, April 1938, page 39.

Directional Antenna Chart—W. S. Dutera—*Electronics*, Vol. XIII, Feb. 1940, page 33.

Increasing Radiation at Low Frequencies—M. G. Morgan—*Electronics*, Vol. XIII, July 1940, page 33.

Vertical vs. Horizontal Polarization—G. H. Brown—*Electronics*, Vol. XIII, Oct. 1940, page 20.

Differential Modulation Meter—V. V. Gunsolley—*Electronics*, Vol. XIII, Jan. 1940, page 18.

Frequency Modulation—A Revolution in Broadcasting?—*Electronics*, Vol. XIII, Jan. 1940, page 10.

High-Frequency Broadcast Chart—*Electronics*, Vol. XIII, Dec. 1940, page 41.

WEAF, Port Washington Station—*Electronics*, Vol. XIII, Sept. 1940, page 20.

Air Cooling Applied to External-Anode Tubes—E. M. Ostlund—*Electronics*, Vol. XIII, June 1940, page 36.

Frequency Modulation Applied to a Television System—C. W. Carnahan—*Electronics*, Vol. XIII, Feb. 1940, page 26.

Interspersed Frequency Modulation and Amplitude Modulation in a Television Signal—A. V. Loughren—*Electronics*, Vol. XIII, Feb. 1940, page 27.

Modulation Limits in Frequency Modulation—Black & Scott—*Electronics*, Vol. XIII, Sept. 1940, page 30.

Transmitting Antenna is Iced at Alpine, N. J.—*Electronics*, Vol. XIII, May 1940, page 19.

WOR's F-M Station (On the Air 105 Hours per Week)—*Electronics*, Vol. XIII, Sept. 1940, page 17.

State-Wide F-M Police Network—D. E. Noble—*Electronics*, Vol. XIII, Dec. 1940, page 28.

Flexible Beam Power Transmitter—E. F. Kiernan—*Electronics*, Vol. XIII, Aug. 1940, page 40.

[Continued on page 58]



The NEW RCA Type 715-A

Laboratory-type OSCILLOSCOPE Triggered Sweep and Time-Base Marker

A "custom-built" design now available for the first time for general use—especially suited for war work—ideal for post-war problems.

10 Important Features

- 1 Triggered sweep—individually triggered by each signal.
- 2 Time-base marker; one microsecond intervals.
- 3 Sinusoidal horizontal spot deflection at power line frequency with adjustable phase control.
- 4 Extended frequency range — vertical amplifier flat to 10 megacycles.
- 5 High vertical deflection sensitivity (.66 volts/inch).
- 6 Precisely compensated attenuator for vertical amplifier.
- 7 Calibration meter to permit direct determination of amplitude of any voltage component in signal.
- 8 Low input capacity and high input resistance for vertical amplifier.
- 9 Complete absence of cross-coupling between horizontal and vertical deflection circuits.
- 10 Regulated power supply to insure steady pattern on screen independent of line voltage changes.

For complete details, send for bulletin

Deliveries of this instrument will be as scheduled by WPB approved Form 3243 under Scheduling Order M-293. Please address inquiries to Test and Measuring Equipment Section, RADIO CORPORATION OF AMERICA, Camden, New Jersey.



RADIO CORPORATION OF AMERICA

RCA VICTOR DIVISION • CAMDEN, N. J.

LEADS THE WAY... In Radio... Television... Tubes...
Phonographs... Records... Electronics

1 Sudden condenser charge and subsequent discharge as seen on ordinary oscilloscope.



2 Externally synchronized and expanded 50 times, revealing the true form of one of the charges in Fig. 1.



3 The same charge, expanded 1000 times, permits detailed observation of the wave front.



4 Applying a one-microsecond time-base marker allows determination of time intervals during the cycle.



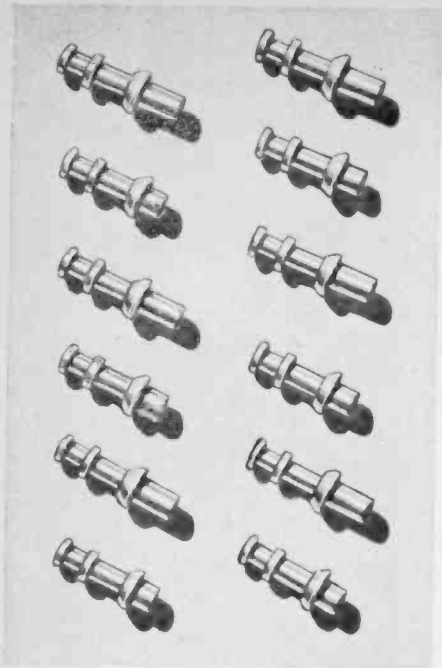

TURRET LUGS

To Meet YOUR Board Thicknesses

Just tell us the thickness of the terminal boards on which you wish to use them, and in short order these fine, precision made, heavily silver plated Turret Lugs will be on their way to you.

You'll like these Lugs. Just swage 'em to the boards and in a jiffy you have good firm Turret Terminals that are convenient for soldering and that make lasting, dependable contacts.



Order them by mail, phone or wire from

CAMBRIDGE Thermionic CORP.

454 CONCORD AVENUE
CAMBRIDGE 38, MASSACHUSETTS



BIBLIOGRAPHY

[Continued from page 56]

Power Amplifier Plate Tank Circuits—A. B. Newhouse—*Electronics*, Vol. XIV, Nov. 1941, page 32.

KCMO's 5-KW Transmitter—L. C. Sigmon—*Electronics*, Vol. XIV, Aug. 1941, page 18.

Push-button Switching for the Small Broadcaster—H. H. Wood—*Electronics*, Vol. XIV, May 1941, page 32.

Standard Broadcasting Reference Data—*Electronics*, Vol. XIV, June 1941, page 40.

Design Chart for R-F Heat Treatment Generators—E. Mittelmann—*Electronics*, Vol. XIV, Sept. 1941, page 51.

Electron Tubes in Petroleum Research—Penther & Pompeo—*Electronics*, Vol. XIV, May 1941, page 43.

Low-Power Transmitter for Demonstrating Frequency Modulation Receivers—M. Hobbs—*Electronics*, Vol. XIV, Jan. 1941, page 20.

Measurements in Frequency Modulation Transmitters—H. P. Thomas—*Electronics*, Vol. XIV, July 1941, page 36.

Binaural Transmission on a Single Channel—Eastman & Woodward—*Electronics*, Vol. XIV, Feb. 1941, page 34.

Low Power Transmitter for Demonstrating Frequency Modulation Receivers—M. Hobbs—*Electronics*, Vol. XIV, Jan. 1941, page 20.

Power Amplifier Plate Tank Circuits—*Electronics*, Vol. XIV, Nov. 1941, page 32.

Choice of Tubes for Wide-Band Amplifiers—D. Pollack—*Electronics*, Vol. XII, April 1939, page 38.

Ultra-High Frequency Power Amplifier of Novel Design—A. V. Haefl—*Electronics*, Vol. XII, Feb. 1939, page 30.

Antenna Radiation Chart—L. J. Giacometti—*Electronics*, Vol. XII, Feb. 1939, page 30.

Central Antenna System—D. J. Fruin—*Electronics*, Vol. XII, Nov. 1939, page 37.

Testing the Shunt-Fed Antenna—*Electronics*, Vol. XII, Dec. 1939, page 42.

Applying Feedback to Broadcast Transmitters—L. G. Young—*Electronics*, Vol. XII, Aug. 1939, page 20.

Frequency-Modulated Transmitters—*Electronics*, Vol. XII, Nov. 1939, page 20.

WSOC's Pack Type Transmitter—S. T. Carter—*Electronics*, Vol. XII, April 1939, page 29.

Recent Advances in Frequency Modulation Transmitter Installations—*Electronics*, Vol. XII, Feb. 1939, page 36.

Tallest U. S. Broadcast Tower—C. Todd—*Electronics*, Dec. 1943, page 104.

Adjusting Unequal-Tower Broadcast Arrays—G. H. Brown & J. M. Baldwin—*Electronics*, Dec. 1943, page 118.

Volume Compressor for Radio Stations—G. Q. Herrick—*Electronics*, Dec. 1943, page 135.

Impulse Generator for Measuring High-Power Tubes—J. H. O. Harries—*Electronics*, Dec. 1943, page 136.

Choosing Tube Types

[Continued from page 34]

likely to exceed the tube rating. Rectifier operation characteristic curves for choke or condenser input to the

filter are shown in tube manuals. Knowing the d-c voltage and current requirements it is only necessary to find where these values intersect the rms volts per plate curve to determine the voltage required in the transformer secondary.

[To be concluded]

THIS MONTH

[Continued from page 38]

The theory, held by nearly all scientists, is that magnetism has force and power, but no movement—unlike electric current in which electrons flow along a copper wire. Professor Ehrenhaft's theory that magnetic current can be generated by a permanent magnet, if proved correct, would mean the establishment of an entirely new source of power and would necessitate a complete revamping of currently-held theories in physics.

Describes Experiments

Dr. Goldman, who is in charge of permanent research at the Westinghouse Research Laboratories, addressed the meeting at the conclusion of a talk given by Professor Ehrenhaft who outlined the experiments which led him to believe in the existence of magnetic current.

The Westinghouse physicist described to the meeting a series of four experiments on which his conclusions to the negative were based.

In the first, Dr. Goldman said, he placed a solution of sulfuric acid in a glass tube between the poles of a horseshoe-shaped permanent magnet. The iron surface of the poles was covered with paraffin in order to prevent a chemical reaction between the iron and the water, which would result in the liberation of hydrogen.

"In this experiment, bubbles soon appeared in the solution," Dr. Goldman reported. "If these bubbles were the result of liberated oxygen caused by a magnetic current passing through the water, then it would seem that there was a movement or flow of current from one pole of the magnet to the other. But since the magnet did not lose any of its strength, we concluded that these bubbles were caused by dissolved air and oxygen in the solution."

In the experiments conducted by Dr. Ehrenhaft, the Viennese scientist said the permanent magnet lost 15 per cent of its strength while in a similar acid solution, thus leading the physicist to conclude that actual magnetic particles had flowed from the poles into the solution.

Acid Solution Boiled

To test his first conclusion, Dr. Goldman continued, a second experiment was made. The acid solution was boiled to drive off the dissolved air and oxygen. Then the paraffin-coated poles of the magnet were again immersed in the solution. This time no bubbles appeared, Dr. Goldman said, supporting the conclusion that no magnetic current had passed between the poles of the magnet, and that

[Continued on page 62]

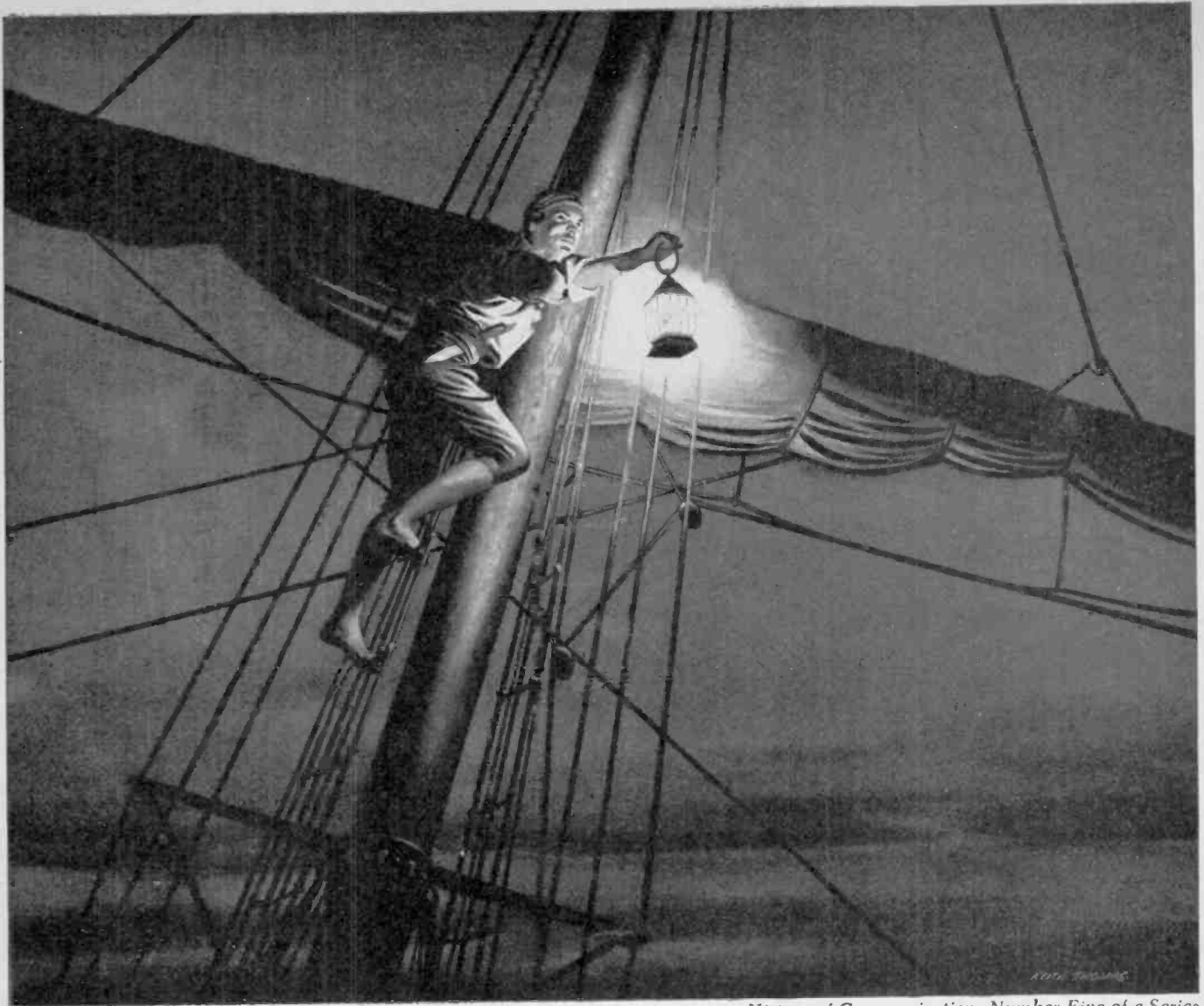

History of Communications Number Five of a Series

NIGHT COMMUNICATIONS ON THE HIGH SEAS



MODEL T-30-S
THROAT MICROPHONE



In those early days when our Navy was first organized night communication was made by lantern from the masthead. This was the only communication between ships at sea during through which many times news from home was transmitted.

Today, through the use of Universal Microphones and voice communication components, vital communications of War are speedily transmitted equally as well from small sea-craft and battle cruiser to home port.

Many new types of Universal microphones shall be developed from the experience obtained from the production of military units, for the private citizens in the marine pleasure-craft in the days after Victory is ours.

< Model T-30-S, illustrated at left, is but one of several military type microphones now available to priority users through local radio jobbers.

UNIVERSAL MICROPHONE COMPANY
INGLEWOOD, CALIFORNIA



FOREIGN DIVISION: 301 CLAY STREET, SAN FRANCISCO 11, CALIFORNIA -- CANADIAN DIVISION: 560 KING STREET WEST, TORONTO 1, ONTARIO, CANADA

RADIO

★ JUNE, 1944

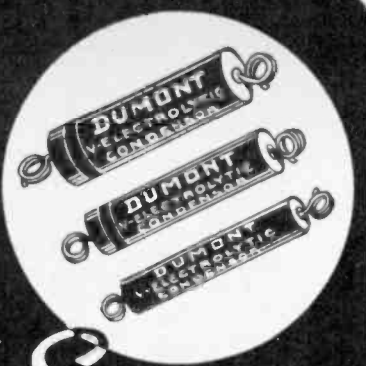

Serving
UNCLE SAM
 WITH THE NEW
DUMONT
VICTORY MODEL TE
SUPERCAPS

Dumont Electrolytic tubulars for the duration have the following special features...and are guaranteed to give the same high quality performance for which all Dumont Electrolytic Tubulars have a reputation.

SELF HEALING
 LONG LIFE
 ECONOMICAL
 VARNISHED TUBES
 DOUBLE SEALED
 SMALL SIZE
 FULLY GUARANTEED
 Patent Pending

BUY
 WAR
 BONDS

DUMONT
ELECTRICO.
 MFR'S OF
 CAPACITORS FOR EVERY REQUIREMENT
 34 HUBERT STREET
 NEW YORK, N. Y.

TECHNICANA

[Continued from page 16]

to show that the impedance of an antenna system is the same for reception and transmission. He does this by logical argument that the two theorems apply to the antenna as a linear system.

This is interesting because it has been frequently suggested by other authors that the impedance, effective height, and polarization may not be the same for transmission and reception.

It is also shown that the effective height of an antenna is the same for both conditions. The Reciprocal Theorem of Helmholtz is invoked in this discussion. The effective height of a simple receiving antenna is given as the ratio of the induced emf appearing at its terminals to the incident plane polarized field intensity producing it.

For a complex antenna system the effective height is defined in terms of the direction of transmission and polarization.

The author also discusses critically the four methods of calculating antenna impedance: (a) The method based directly on the Maxwell field equations, (b) The Poynting vector method, (c) The induced emf method, and (d) The transmission line method.

The simplifying assumptions customarily used in these four methods are (a) sinusoidal distribution of current, (b) zero current at the end of an open aerial, (c) concentration of current and charge along the axis, and (d) perfect conductivity.

HARMONIC SYNTHESIS

★ A machine for the addition of harmonic waves is described in an article in the March, 1944, issue of *Proceedings of the Physical Society*, London. The author, A. Shilton, was at a loss for a simple means of demonstrating to his students at Brighton Technical College the resultant wave shapes formed by the addition of harmonic components.

The machine he devised performs the synthesis mechanically by use of a system of cams and pistons. A main crank shaft drives the cams, which are driven by interchangeable gears. An oil-filled cylinder collects this data from all the pistons and records the data on a revolving cylinder as the sum of all motions transmitted to it.

The frequencies to be added depend on the gear ratios selected to drive the cams. The amplitudes of the components are adjusted by the use of

different cams. The phase relationships are varied by adjusting the orientation of the cams with respect to their driving gears.

The chief difficulty in construction was in obtaining oil-tight pistons and cylinders. To do so they were fitted to an accuracy of .0001".

The machine constructed by the author appears to have used three gear-cam arrangements, but undoubtedly the system could be enlarged to permit the addition of any number of harmonic components.

STANDARD FREQUENCY SOURCE

★ H. L. Clark and H. Johnston of the General Electric Company describe a standard 60-cycle frequency source which is accurate to within .02% in frequency, in an article appearing in the May, 1944, issue of the *General Electric Review*.

With an input varying between 105 and 125 volts at 50 to 70 cycles, the output up to 25 watts contains less than 2% harmonic content.

The oscillator is controlled with a "Magnivar" tuning fork which has low thermal expansion, low amplitude coefficient of stiffness, and low temperature coefficient of stiffness. The frequency-temperature coefficient of the tuning fork is therefore less than plus or minus .0004%/°C. A change in amplitude of 1% produces a frequency change of approximately .001%.

The low harmonic content is obtained by the use of filters and inverse feedback in the power amplifier.

A vibration of the tuning fork, which is equipped with a small alnico magnet on each tine, generates a voltage in the tuning fork pick-up coil. This is applied to one of the grids of a 6SN7 through a step-up transformer and capacitor. This voltage is amplified and applied to the tuning fork driver coil. This maintains the vibration.

The output of the tuning fork pick-up coil is also fed into the second grid of the 6SN7 through a capacitor. There the voltage is amplified, stepped up by a transformer, and rectified in one of the diode sections of a 6B8. The rectified d-c is applied to the first grid of the 6SN7 as bias.

SAVING POWER OF CW TRANSMITTERS

★ The usual cw transmitter is "on" during periods of dots and dashes (so-called "mark") and off during the periods in-between ("space"). Consider transmitter would only be on for a very short time at the moment a dot or dash erable power can be saved if the trans-

[Continued on page 62]

QUARTZ CRYSTALS

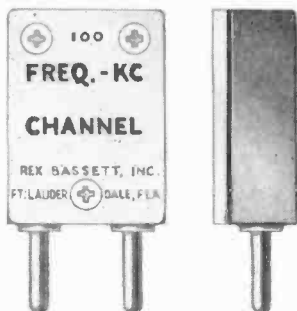

TYPE 100

- 2,000 KC to 10,000 KC
- Tolerance .005% — .01% — .02%
- Two Mount in Octal Socket

Shown Actual Size



TYPE 200

- 1,000 KC to 10,000 KC
- Tolerance .005% — .01% — .02%
- Banana Plugs Spaced .750"

Shown Actual Size

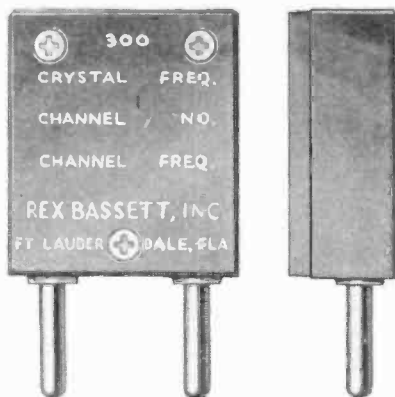

TYPE 300

- 2,000 KC to 10,000 KC
- Tolerance .005% — .01% — .02%
- Plugs in 5 Prong Socket

Shown Actual Size

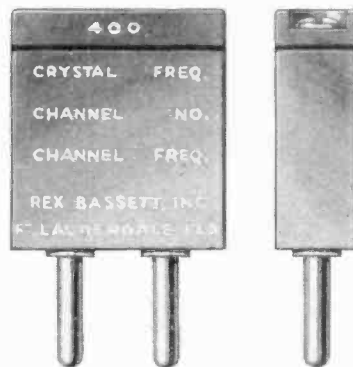

TYPE 400

- 4,000 KC to 10,000 KC
- Tolerance .005% — .01% — .02%
- Straight Pins .500" Spacing

These crystals are manufactured to the highest standard of quality by the most modern equipment and precise means known to the art. All units are scientifically adjusted by X-Ray and, before shipment, are thoroughly tested for frequency, drift, and activity, throughout your specified temperature range.

When ordering simply select the type that meets your requirements as to physical dimensions consistent with the crystal frequency. Specify the desired tolerance, operating temperature range and permissible drift from nameplate frequency throughout this range, and the type of oscillator tube and circuit in which the unit will be used.

Telephone, telegraph, or write for prices on any quantity from one to ten thousand units of any type. Our engineering department will be very happy to co-operate with you.



REX BASSETT
INCORPORATED
FORT LAUDERDALE, FLORIDA.



MR. LITTLE and MR. BIG

One wants radio and electronic components and equipment in dozen units—the other calls for hundreds. One needs help on priorities—the other has a ticklish technical problem. One can use non-critical parts—the other asks for made-to-order apparatus. Big or little, whatever the requirements, Lafayette Radio Corporation acts as a friendly cooperative agent. As leaders in the field, we have the confidence of leaders. We service industry, government agencies, the military forces, schools, laboratories, dealers, etc. Why don't you, too, get acquainted with the Lafayette Radio Corporation's method of doing business?

DON'T LET IT GO TO WASTE . . . SEND WASTEPAPER INTO THE FIGHT

Note! Write or wire for our new 8-page circular listing needed radio parts, available for immediate delivery . . . coils, controls, speakers, condensers, relays, switches, resistors, transformers, etc. All merchandise subject to prior sale. DEPT. F-6

Lafayette Radio Corp.

901 W. Jackson Blvd. 265 Peachtree Street
CHICAGO 7, ILLINOIS ATLANTA 3, GEORGIA

TECHNICANA

[Continued from page 60]

is to be started and the moment it is to be finished. Such pulses should then at the receiver be made to open and close a relay or to start and stop a local oscillator. Such a system is proposed by R. C. Whitehead in an article entitled "Morse by Pulses" appearing in the *Wireless World* for April, 1944.

The author shows how the total time of radiation at full power for transmission at 24 words per minute would be reduced to 1/66. For greater signalling speeds it would be reduced less and for slower speeds more.

The system consists in having pulses transmitted when the key is closed and when the key is opened and to have these pulses operate a relay at the receiving end as desired. In order to have the receiver distinguish between the two pulses they must differ in some fashion. They could be of different carrier frequency, have a different modulation frequency or be of differ-

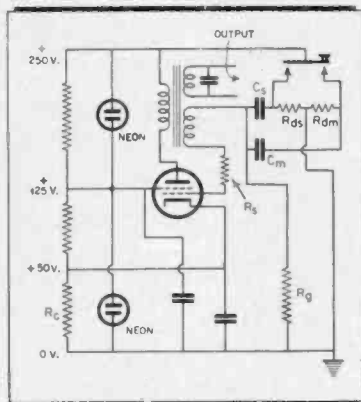

Figure 7

ent duration. The author chooses the latter; the rest of the article is devoted to showing how the pulses are generated and how they are separated in the receiver. This story is too involved to be repeated here, so that we can only give an abbreviated description.

Let us call the pulse which is to be given at the beginning of a dot or dash the "mark" pulse and the pulse at the end of a dot or dash the "space" pulse. The mark pulse is to be twice as long as the space pulse. Fig. 7 shows the diagram of the pulse generator at the transmitter. If the key is in the up or "space" position and has been there for some time, the condenser C_s is charged and the grid of the tube is at chassis potential; the cathode potential is so high that the tube is biased beyond cut-off. When the key is pressed, the condenser C_s will first be dis-

charged through R_{ds} and R_g ; this has no effect upon the circuit. However, when the key is down, C_m will be charged through R_{dm} and R_g and the charging current through R_g will cause a voltage drop so that the grid becomes temporarily positive and plate current can flow. The grid cannot rise above the cathode potential due to the grid current through R_S . When the charging current decreases and the plate current also diminishes, an emf will be induced in the transformer winding in the grid circuit in opposition to the potential difference across R_g . The tube is then suddenly cut off. The length of the pulse is determined by the time constant of the circuit. As the key is lifted another pulse of shorter duration is generated, since the values of R_{ds} and C_s have been so chosen as to provide the shorter time constant.

At the receiver the two pulses are applied to a clipper tube which insures that they shall all have the same amplitude. The pulses applied to an integrating circuit result in the longer one being able to raise the potential of a condenser sufficiently to fire a gaseous triode, while the shorter pulse cannot.

The narrow-pulse admittor is a tube, similar to a 6L7, which is so biased that both grid No. 1 and grid No. 3 must be made positive to make plate current flow. By means of differentiating and delay circuits it is arranged that only a narrow pulse can produce a momentary positive voltage simultaneously at both the No. 1 and No. 3 grids. This tube then draws current for a short while and the resultant momentary voltage drop across the plate load is caused to drop the plate voltage of the gaseous triode sufficiently to extinguish it.

THIS MONTH

[Continued from page 58]

the bubbles had been caused by the action of dissolved air and oxygen.

"In the third experiment," he reported, "the paraffin coating was removed and the iron surface of the magnet poles brought into direct contact with the acid solution.

"Here there were violent bubbles caused by the liberation of hydrogen as a result of the chemical reaction between the iron and the acid solution. But the magnet still retained its original strength, indicating that no magnetic current was being drawn off from the poles."

Magnetic Flow Unproved

As a final check, Dr. Goldman said, the entire pole structure was covered with paraffin, except the pole faces which were left bare, and then immersed in sulfuric acid of a much higher concentration. It was allowed to remain in solution for many hours.

[Continued on page 66]

Sperti HERMETIC SEALS

NOW IN

Volume production

Arm your equipment to meet tough military conditions—anywhere—with these improved Hermetic Seals that seal out dust, humidity, moisture and fungus from transformers, relays, vibrators and other sensitive component parts.

FUSED INTO ONE PIECE. Vacuum tight hermetic bond. Resists corrosion. Has thermal operating range of -70°C to 200°C . Insulation leakage resistance, 30,000 megohms, minimum, after Navy immersion test.

SOLDERING TEMPERATURE NOT CRITICAL. Simple, easy to attach by means of high frequency, oven-soldering, or standard soldering iron.

WRITE, WIRE OR PHONE TODAY for information. Send us complete details on your problem so we can offer specific recommendations and furnish samples.

Sperti INCORPORATED

RESEARCH, DEVELOPMENT, MANUFACTURING · CINCINNATI, OHIO

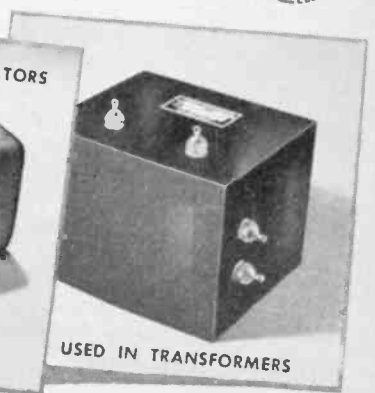
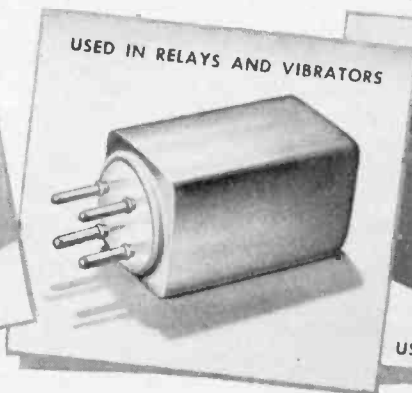
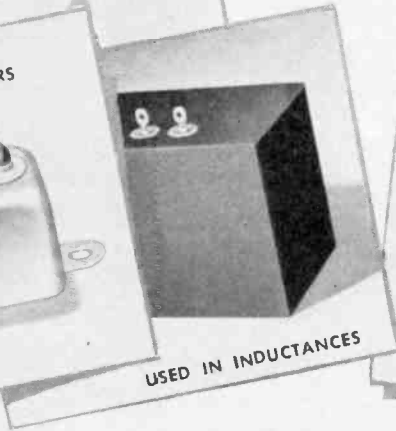
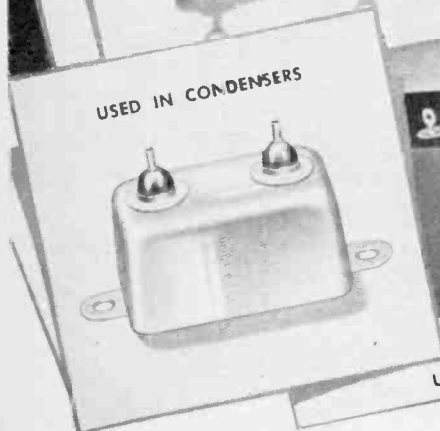
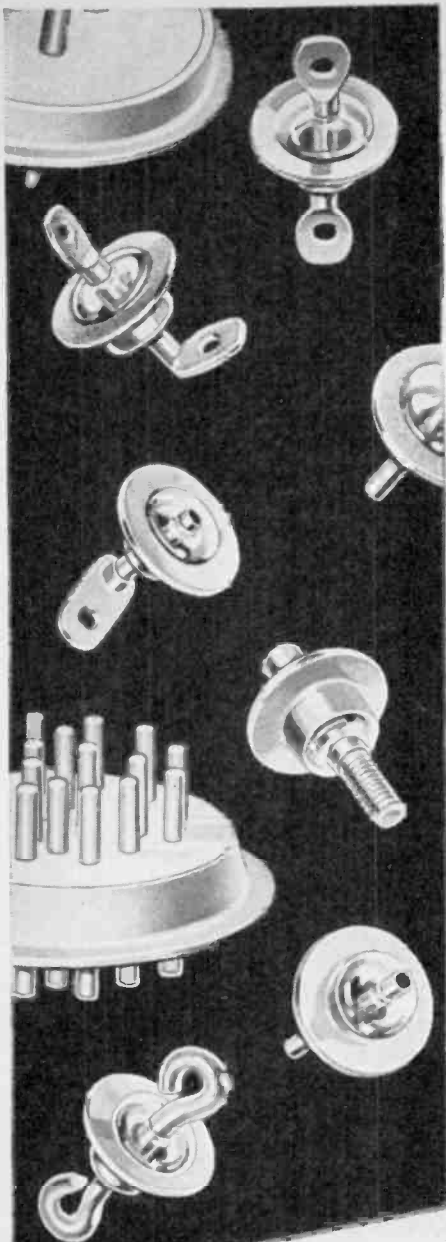

RADIO WIRE & CABLE

[Continued from page 31]

detrimental as a contributor to moisture absorption under high-humidity conditions with consequent decrease of leakage resistance. In any event, the increased diameter is definitely objectionable.

A textile outer covering in the form of a wrap or braid of cotton, silk, nylon, rayon, or fiber glass is commonly employed. There are arguments both for and against such a covering as follows:

Advantages

1. Improved abrasion resistance.
2. Support for thermoplastics per-

mitting use at higher ambient temperature.

3. Enables wide selection of color combinations through use of tracers.

Disadvantages

1. Increased diameter and weight.
2. Decreased leakage resistance under high-humidity conditions.
3. Decreased resistance to fungi and vermin.
4. Increased inflammability (organic materials only).

The last three disadvantages may be reduced to little consequence through the use of suitable impregnants and lacquer coatings. It is usually considered therefore that a textile covering is desirable provided that the additional diameter can be tolerated.

Selection:—From the foregoing, it should be evident that no single type of hook-up wire will meet every requirement. Four to six types judiciously selected, however, should suffice.

Of first importance is the primary insulation. Buna S and butyl rubber, although relatively new in this field, will be the materials most generally available for the duration. These synthetic rubbers are much like the natural product, having excellent dielectric properties but rather poor resistance to oils. The vinyl polymers and copolymers, on the other hand, are highly oil resistant and have been used successfully for several years. Recently, critical shortages of the latter materials have developed but these will be alleviated by an expansion of manufacturing facilities now in process. Cellulose acetate butyrate tape is advantageous with respect to diameter increase but offers inadequate resistance to moisture and abrasion, both probably due to the method of application rather than the material.

The two most important dielectric properties of any insulating material are dielectric strength and insulation resistance. In radio-frequency circuits, power factor and dielectric constant also assume importance from the standpoint of energy losses. All of the materials designated for primary insulation have adequate dielectric strength but wide variations are to be found in insulation resistance, power factor, and dielectric constant. Vistanex and polythene are exceptionally low-loss materials but their present use is restricted by government allocation to high-frequency applications. Next best are Buna S and butyl rubber and following these are the vinyl compounds.

Temperature is a vital factor to be considered in all synthetics as well as in natural rubber. The allowable temperature rise with respect to maximum

ambient temperature for the more important rubber and rubber-like compounds are included in *Fig. 1*. Any attempts to exceed these limits are ill-advised since the natural and synthetic rubbers will deteriorate rapidly and the plastic elastomers will soften and deform. The dielectric properties also are adversely affected by increasing temperature. As shown in *Fig. 6*, the d-c resistivity (meg. cm) of a typical vinyl compound at 60° C. (140° F.) is only about 1/100th of the value at 30° C. (86° F.). It is also important that the insulation shall not crack at sub-zero temperatures. The vinyl insulations have been limited in this respect but compounds that will withstand reasonable bending at -50° C. (-58° F.) have recently become available. It appears also that Buna S and butyl rubber have satisfactory cold bending properties approaching those of natural rubber.

The selection of an appropriate textile material for the insulation covering involves many considerations. Perhaps most important is the addition to the diameter and *Fig. 7* has been prepared to illustrate the approximate overall diameters that may be expected for fiber glass and cotton braids over vinyl insulation (curves 4 and 5) throughout the range of A.W.G. sizes #8 to #22. The additional curves for vinyl compound without textile reinforcement (3), for cellulose acetate butyrate tape covered by a glass braid (2), and for the bare conductor (1) are included from the standpoint of general interest. With vinyl insulation, textile reinforcement is particularly desirable in that the maximum permissible operating temperature is thereby increased from 60° C. (140° F.) to 75° C. (167° F.). Such improvement is obtained irrespective of the material used. The glass-braided type although smaller, non-inflammable, and resistant to fungus growth has poor abrasion resistance, develops objectionable corona discharge at frayed ends on relatively low voltages, transmits moisture rapidly along the surface by "wicking" action, and can not be colored successfully. Circuit identification may be obtained by the insertion of colored rayon tracers against the natural white background of the glass fibers but the braid is then rendered inflammable. Cotton braid produces larger diameters but is highly resistant to abrasion, does not develop excessive corona, and can be coded in solid colors as well as tracers. It can also be impregnated to resist flame, moisture, fungi, and vermin.

In the field of synthetic textiles, there are two additional materials

[Continued on page 66]

Do You Need Trained Help?

For many years we have been training and placing men for electricity, radio, and electronics. Write and tell us about the jobs you have open. Whether in immediate need of help or not, registering your company with our Placement Service gives you first choice of available National trained men in your vicinity.

NATIONAL SCHOOLS

Established 1905

4000 South Figueroa Street
Los Angeles 37, California



BURSTEIN-APPLEBEE CO.
1012-1014 McGee St. • Kansas City 6, Missouri

RADIO

GROUP SUBSCRIPTIONS SAVE YOU UP TO 50%!

TEAR OUT—MAIL TO RADIO

RADIO MAGAZINES, INC.

342 Madison Ave., New York 17, N. Y.

Kindly enter the following subscriptions. Remittance is attached. (1 to 6 subscriptions may be ordered on this form).

- One 1-year subscription \$3.00
- Two 1-year subscriptions \$5.00
- Three 1-year subscriptions \$6.00
- Four 1-year subscriptions \$7.00
- Five 1-year subscriptions \$8.00

Groups of 6 or more subscriptions in the U.S.A. will be accepted at the rate of \$1.50 each. For Canadian groups add \$.50 to each subscription ordered.

PLEASE PRINT

Name

Address

Position Company

Name

Address

Position Company

Name

Address

Position Company

Name

Address

Position Company

Name

Address

Position Company

Name

Address

Position Company

NOTE: If you do not wish to tear out this order blank, print or type a list giving each subscriber's name, address, employer's name and their respective positions. Mail it in today!



You and your co-workers can now save up to half the regular cost of a RADIO subscription by using the Group Plan. The more men in a Group the more each saves, up to 50%. Present subscriptions may be RENEWED or EXTENDED as part of a group.

The combination of exclusive, fine and timely articles plus this low-rate subscription offer makes RADIO a must-have publication. So fellows, form a Group today and send it to—

RADIO MAGAZINES, INC.

342 MADISON AVENUE NEW YORK 17, N. Y.

Wanted ENGINEERS

- Radio
- Chemical
- Electrical
- Electronic
- Mechanical
- Metallurgical
- Factory Planning
- Materials Handling
- Manufacturing Planning

Work in connection with the manufacture of a wide variety of new and advanced types of communications equipment and special electronic products.

Apply (or write), giving full qualifications, to:

C. R. L.

EMPLOYMENT DEPARTMENT

Western Electric Co.

100 CENTRAL AV., KEARNY, N. J.

Applicants must comply with WMC regulations

Here's How You Can Figure . . . —On a BETTER Job and a Secure Career in RADIO - ELECTRONICS

CREI home study training in Practical Radio-Electronics Engineering equips you with the ability to go after—and get—a better, secure engineering job.

After the war, will come the period of the "survival of the fittest." Employers can then once again afford to be "choosy" in selecting the best-trained men for the best jobs.

In our proven course of training, you learn not only how . . . but why! Your ability to solve tough problems on paper, and then follow up with the necessary mechanical operation is a true indication that you have the confidence born of knowledge . . . confidence in your ability to get and hold an important job with a secure, promising future . . . These jobs are waiting today for radiomen with up-to-date technical training.

Investigate CREI home study training now, . . . and prepare for security and happiness in the coming New World of Electronics!

Write for Details

About CREI Home Study Course

If you are a professional or amateur radioman and want to make more money—let us prove to you we have something you need to qualify for the BETTER career-job opportunities that can be yours. To help us intelligently answer your inquiry—PLEASE STATE BRIEFLY YOUR EDUCATION, RADIO EXPERIENCE AND PRESENT POSITION.



CAPITOL RADIO

ENGINEERING INSTITUTE

Dept. RA-6, 3224-16th St., N.W., Washington 10, D.C.

RADIO WIRE & CABLE

[Continued from page 64]

worthy of mention—rayon and nylon. Rayon braids are exceptionally fine in appearance but are much less resistant to abrasion than cotton. Nylon, although not being used commercially for braiding, is known to possess excellent abrasion resistance but is not heat or flame resistant and appears to be incapable of impregnation and coloring. Both of these synthetics afford diameter increases intermediate between those of fiber glass and cotton.

Textile outer coverings, when employed should always be coated with a transparent, flexible lacquer to obtain a hard, smooth, glossy surface of high resistivity. It is important that the lacquer shall be chemically inert to avoid reaction through contact with metallic and painted surfaces in the equipment under elevated temperatures. Excessive thickness also may lead to cracking and flaking. Satisfactory results should be obtained with a coating of good quality cellulose-acetate lacquer not over 0.010 inch thick.

Conclusion

There can be but one conclusion to be drawn from this article—the fact that no perfect insulation is yet available. Considerable progress has already been made in the development of new and better dielectric materials for electric conductors and there is good reason to believe that even greater improvements will be disclosed in the near future. Full cognizance of the limitations of present types of radio wire and cable is essential to the design of economical and reliable electrical equipment.

References

5. "NEMA Magnet Wire Standards." Published by National Electrical Manufacturers Association, Washington, D. C.
6. "Synthetic Materials as Wire Insulation" by Winton Patnode, E. J. Flynn, and J. A. Weh. *Electrical Engineering*, September 1939, Vol. 58, No. 9, pp. 379-388 incl.
7. "Internal Drying Varnishes for Better Electrical Coils" by George J. Hepp. *Electrical Manufacturing*, April 1944.
8. "Aircraft Transformers—Small and Light" by O. Kiltie. *Electrical Engineering*, March 1944, Vol. 63, No. 3, pp. 84-88.
9. *Wireless World*: Dec. 8 and 15, 1926, pp. 754, 811.
10. *Wireless World*: Dec. 19 and 26, 1928, pp. 834, 864; Jan. 9, 1929, pp. 43-45.
11. "1940 National Electric Code." Standard of the National Board of Fire Underwriters, New York, N. Y.
12. "Plastic Insulations for Conductors" by E. D. Youmans. *Electrical World*, August 7 and Sept. 4, 1943.

CORRECTION

The formula for voltage drop calculation which appeared in the first installment of this article should have read:

$$R_t = R_{t_0} (1 + \alpha_{t_0} [t^\circ - t_0^\circ])$$

where: R_t = resistance at operating temperature t° C.
 R_{t_0} = resistance at initial or reference temperature t_0° C.
 α_{t_0} = temperature coefficient of resistance at initial or reference temperature (as selected).

Also, in Fig. 1, curves 4, 5, and 6, apply likewise to other materials, as indicated in the caption under Fig. 1 in this installment.

THIS MONTH

[Continued from page 62]

"The liberation of hydrogen caused violent bubbling," Dr. Goldman explained, "but at the conclusion of the experiment the strength of the magnet was the same as at the beginning. This result, combined with the findings from the previous three experiments, led us to conclude that there was no flow of magnetic particles between the poles and that the hypothesis of magnetic current is not supported by the evidence."

WESTINGHOUSE AGAIN TO MAKE RADIO RECEIVERS

The Westinghouse Electric and Manufacturing Company, which discontinued the manufacture of home receiving sets in 1928, plans to re-enter this field as soon as war conditions permit, according to *Walter Evans*, Vice President in charge of the Company's Radio Division, Baltimore, Maryland.

"We feel that for several reasons the postwar period offers an unusual opportunity to return to such production," he said. "With the obsolescence and wearing out of a large portion of the approximately fifty million sets in use at the start of the war, the requirements of the public will place demands on the industry far above the prewar volume. Westinghouse, to meet war demands, has enormously expanded its radio capacity. It is now turning out fifty-one times the radio equipment it produced in the prewar years.

When peace comes again, instead of closing down these greatly expanded facilities, with resulting unemployment, we will turn them to the building of home radio receivers. Further, in the period since radios were last built, there have been great technical improvements growing out of the war work, to which the public is entitled in the post-war models.

"We will, therefore, manufacture standard receiving sets and frequency modulation, including phonograph combinations and, as soon as possible, home television equipment. These will be distributed to retailers through the Company's national distributing channels."

★ **He won't dodge this-** ★



Don't you dodge this!

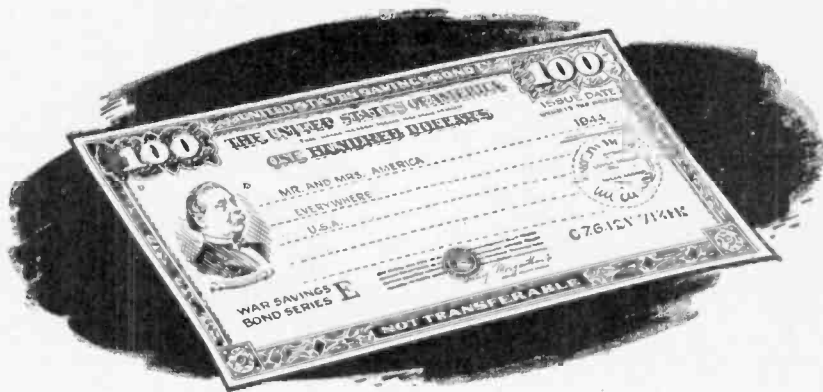

The kid'll be right there when his C. O. finally gives the signal . . .

There'll be no time to think of better things to do with his life. THE KID'S IN IT FOR KEEPS—giving all he's got, *now!*

We've got to do the same. This is the time for us to throw in everything *we've* got.

This is the time to dig out that *extra* hundred bucks and spend it for Invasion Bonds.

Or make it \$200. Or \$1000. Or \$1,000,000 if you can. There's no ceiling on this one!

The 5th War Loan is the biggest, the most vitally important financial effort of this whole War!



***Back the Attack!* - BUY MORE THAN BEFORE**

RADIO

★ This is an official U. S. Treasury advertisement—prepared under the auspices of Treasury Department and War Advertising Council ★

FREQUENCY METER

[Continued from page 27]

of this nature, it will be necessary to count this beat difference by ear. Zero frequency difference will be indicated by the absence of "flutter." With zero beat established between the received signal and frequency meter, the signal frequency may be read from the frequency meter calibration curve, if the signal is in the range of 1 to 2 mc. If it is not, then its frequency is the nearest known multiple of the frequency meter if higher in frequency, or the nearest known sub-multiple if it is lower in frequency. Signal frequency may be roughly determined by receiver calibration.

If it is desired to measure the frequency of transmitter at the point of transmitter location, the following procedure will be satisfactory:

The frequency meter may be located in reasonable proximity to the transmitter whose frequency it is desired to measure, but in no case should the equipment be located so close that the field of the transmitter is in excess of one (1) volt. It is preferable that the field be approximately one-half volt intensity. In the event of a strong field, i.e., 1 volt or more, it is very probable that no external coupling to the unit will be necessary. If the field is of low intensity, a coupling (antenna) wire should be attached to the output post of the equipment and the input signal from the transmitter adjusted to the proper mixing level by means of the gain control on the front panel. The variable frequency oscillator may then be turned to zero beat with the transmitter signal and its dial position noted. The frequency of the transmitted signal may be read directly from the calibration curve, assuming the frequency meter calibrated to have accurately established immediately prior to measurement.

It must be borne in mind that the frequency as determined from zero beating of the heterodyne frequency meter against an external signal will be:

a). A sub-harmonic of the 100 to 2000 kcs. range of the SR-90-A equipment where the external source is known to be below 1000 kc.

b). As indicated by SR-90-A when the external source is known to be in the range of 1000 to 2000 kc.

c). A harmonic of the SR-90-A where the external source is known to be above 2000 kc.

The ambiguity of measurement in (a) and (b) may be resolved from the use of a receiver of calibration sufficiently accurate to determine with which sub-harmonic or harmonic the measurement is concerned.

ADVERTISING INDEX

ADVERTISER	PRODUCT	PAGE
Aerovox Corporation	Capacitors	56
Andrew Co., Victor J.	Co-axial Cables	6
Astatic Corp., The	Microphones, pickups	8
Automatic Elec. Sales Corp.	Relays	47
Bassett, Inc., Rex	Quartz Crystals	61
Biley Elec. Co.	Quartz Crystals	14
Browning Laboratories, Inc.	Test Equipment	49
Burstein-Appleby Co.	Electronic Equip.	64
Cambridge Thermionic Corp.	Lugs & Transformers	14, 58
Capitol Radio Engineering, Inc.	Educational	66
Conn. Tel. & Elec. Div.	Electrical Equip.	2
Dumont Electric Co.	Capacitors	60
Echophone Radio Company	Receivers	41
Eitel-McCullough, Inc.	Tubes & Vacuum Pumps	51
Electro-Voice Mfg. Co., Inc.	Microphones	48
Formica Insulation Co., The	Laminated Plastics	17
Gray Manufacturing Co.	Recording Equip.	10
Guardian Electric Mfg. Co.	Relays	11
Guthman & Co., E. I.	Tuning Units	4
Hallcrafters Co., The	Communications Equip.	1
Harvey Radio Labs., Inc.	Electronic Instru.	58
Hytron Corporation	Tubes	Cover 3
Industrial & Comm'l Electronics	Institutional	9
Industrial Instruments, Inc.	Precision Instru.	54
Jensen Radio Mfg. Co.	Acoustic Equip.	43
Johnson Co., E. F.	Transmitter Comp.	7
Ken-Rad Tube & Lamp Corp.	Electronic Tubes	50
Lafayette Radio Corp.	Radio-Electronic Equip.	62
Merit Coil & Trans. Corp.	Radio Parts	52
National Schools	Educational	64
O'Neil-Irwin Mfg. Co.	Duplicating Mach.	16
Racon Electric Co., Inc.	Speakers	55
Radio Corp. of America	Oscilloscopes	57
Raytheon Production Corp.	Tubes	Cover 2
Sperti, Inc.	Hermetic Seals	63
Sprague Electric Co.	Resistors	45
Standard Transformer Corp.	Transformers	12
Sylvania Elec. Prods., Inc.	Tubes	15
Triplett Elec. Instru. Co.	Portable Instru.	16
U. S. Treasury Dept.	Bonds	67
Universal Microphone Co.	Microphones	59
Western Electric Co.	Help Wanted	66
Westinghouse Elec. & Mfg. Co.	Communications Equip.	Cover 4
Wilcox Electric Co.	Communications Equip.	13
Wrigley Jr., Co., Wm.	Institutional	46

"Right On The Button"

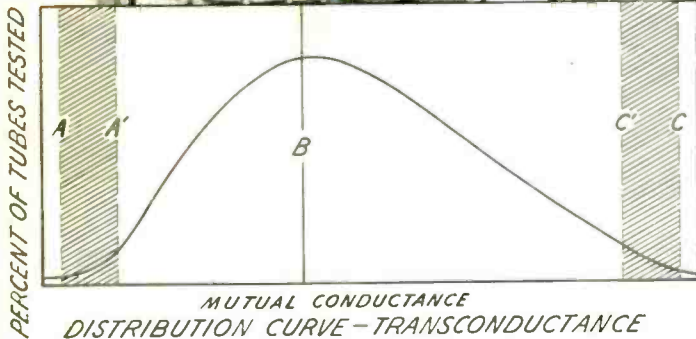
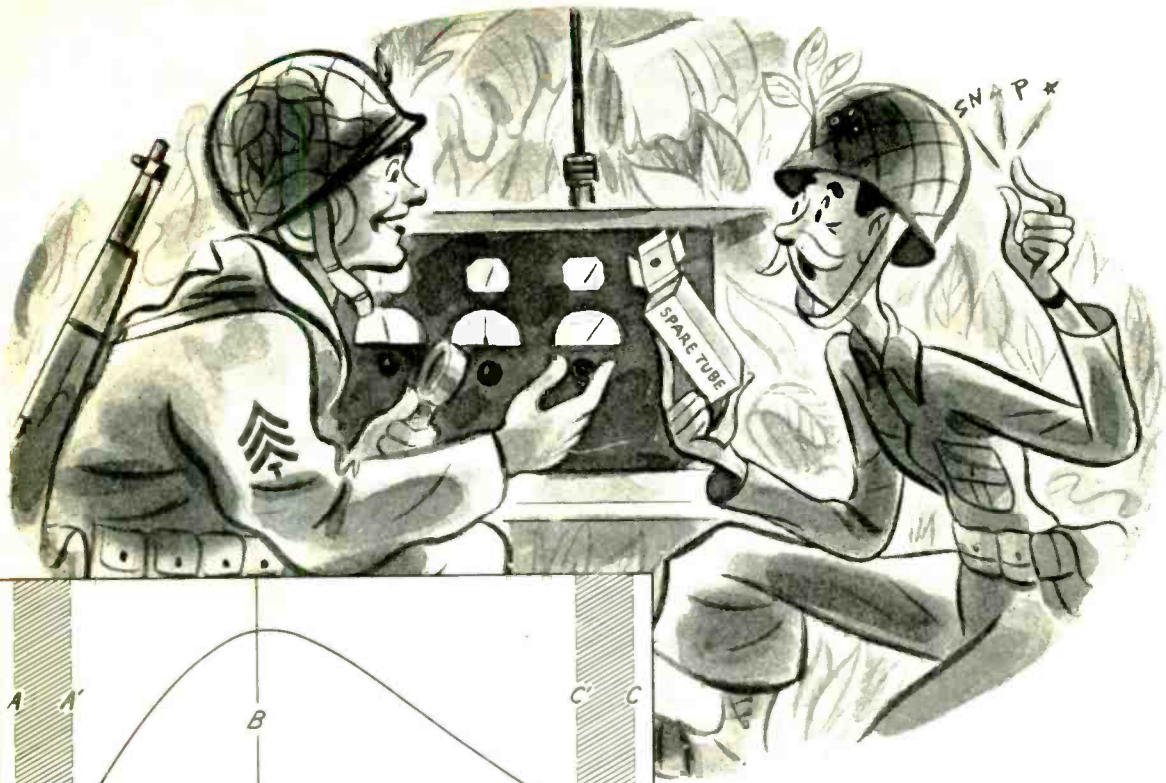

Conscientious electronic equipment manufacturers avoid special selection of tubes. When a battlefield tube replacement is made, they want "on the button" performance. They allow for possible additive effects of tolerances for other components — and for the many minor differences of equipment assembly, wiring, and adjustment. Also they realize it is impracticable to manufacture all electronic tubes of a given type exactly alike. Yet they demand and deserve close observance of their tolerances for each tube characteristic. (See A and C on the distribution curve.) Hytron insists on still tighter fac-

tory specifications. (Compare A' and C'.)

Hytron goes still further. Based on past experience — its own and others' — whenever practicable a "bogie", or desired goal, for each characteristic is set. (Compare B.) Controlled design and production aim at producing the majority of tubes with this preferred value, which is not necessarily and arbitrarily midway between tolerances. It is rather the ideal for peak performance — dictated by experience and attainable if exact duplication were possible.

Specify Hytron for tighter specifications — for "bogie"-controlled production — for uniform performance.



OLDEST EXCLUSIVE MANUFACTURER OF RADIO RECEIVING TUBES

HYTRON
CORPORATION ELECTRONIC AND RADIO TUBES

SALEM AND NEWBURYPORT, MASS.



BUY
ANOTHER
WAR BOND

HERMETIC SOLDER-SEALING

MAKES PRESTITE

TERMINAL BUSHING

Leakage-proof



ACTUAL SIZE

High altitudes . . . humidity condensation . . . thermal shocks . . . cannot affect the performance of Solder-Sealed apparatus. The 100% hermetic bond assured by the metal-to-PRESTITE seal assures trouble-free service of terminal bushings.

The bushing consists of a PRESTITE tube on which are Solder-Sealed a terminal cap and a stud. Similar bushings are available without hardware for Solder-Sealing to other parts on the manufacturer's own production line.

Solder-Sealed PRESTITE assemblies offer immediate help to manufacturers in many available standard forms. They also open up many new and added possibilities in postwar uses. For complete information, send for booklet B-3244. Westinghouse Electric & Manufacturing Company, East Pittsburgh, Pa., Dept. 7-N.

J-05142

Westinghouse
PLANTS IN 25 CITIES . . . OFFICES EVERYWHERE

COMMUNICATIONS EQUIPMENT

INSTRUMENTS
D-C CAPACITORS
HIPERSH CORES



DYNAMOTORS
RECTOX RECTIFIERS
INSULATING MATERIALS



OLD WAY
(SEVEN PIECES)



CONTAINER LID



SOLDER-SEAL

NEW WAY
(ONE PIECE . . . HERMETICALLY SEALED)

Westinghouse Solder-Sealed PRESTITE Terminal Bushing, S & 1309164

Other PRESTITE methods of taking leads through partitions



APPARATUS ENCLOSED SOLDER-SEAL BUSHING—combination insulator, cover and terminal board—has a hollow construction which permits placing small devices inside.



SOLDER-SEAL ASSEMBLY—for vibrator packs, but can be used in similar apparatus, combining jack and terminal board.



SOLDER-SEALED BUSHING—for use with thicker gage covers of larger size transformers and capacitors. Bushing is Solder-Sealed to a metal ring which is soldered to the container cover.

PRESTITE is a dense nonporous ceramic compacted under high pressure and vacuum by the patented PRESTITE method of manufacture. This eliminates minute air pockets in the material, thus minimizing distortion in voltage gradients and eliminating internal corona discharges. PRESTITE is impervious to moisture and all chemicals except hydrofluoric acid. The quality of PRESTITE is consistently uniform, thus eliminating the need for the exaggerated safety factors common in other ceramics.